

Overload Clutches

Positive Torque Limiters • Friction Torque Limiters • Force Limiters

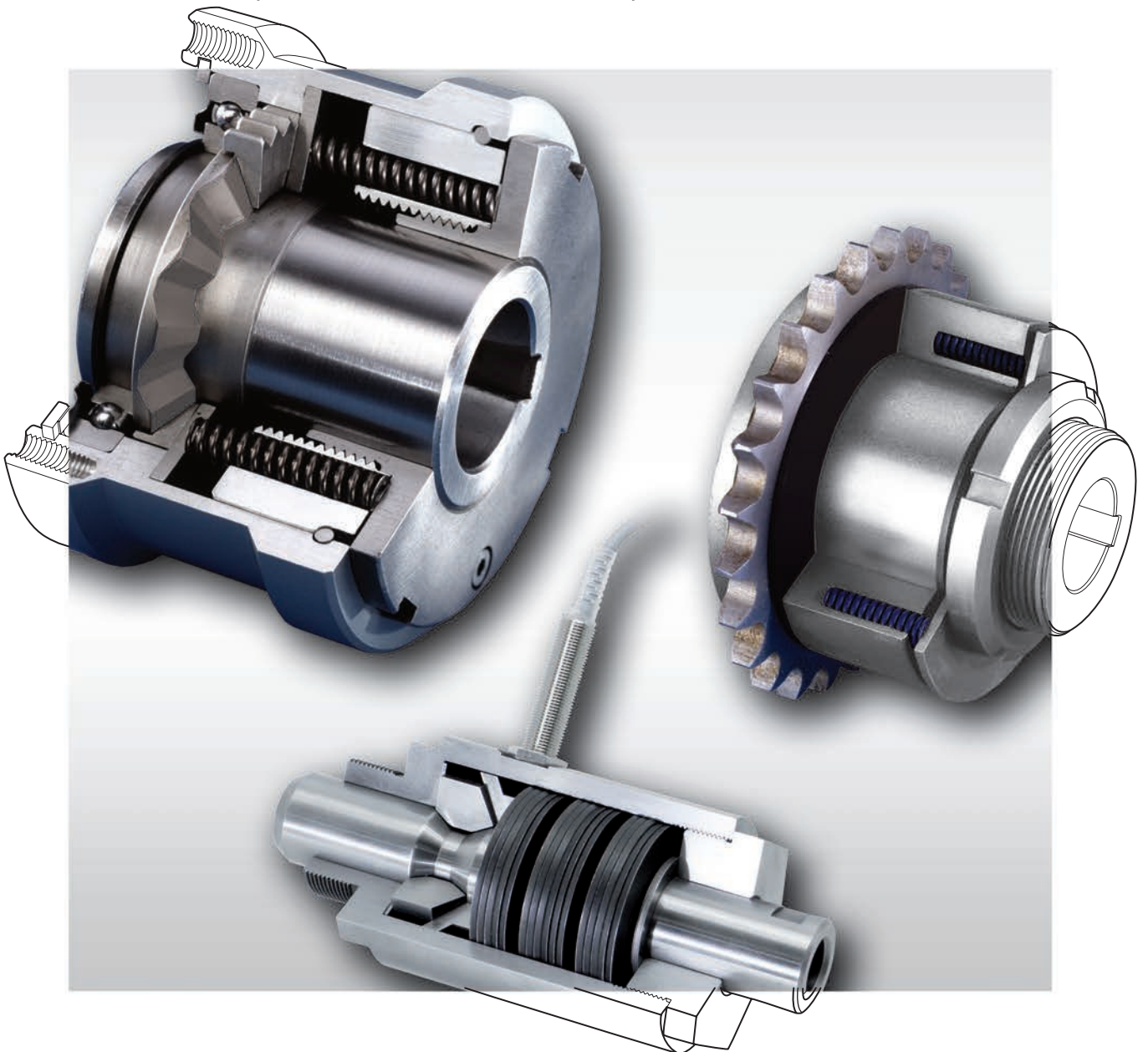

Edition 2023/2024



Table of Contents

Introduction	Page
Introduction Overload Clutches	4
Overview Overload Clutches	6
SIKUMAT®-Torque Limiters	Page
Ratcheting SIKUMAT® SC ... with screw faces	8
Series SC - Basic version with flange connection	10
Series SCE - with flexible shaft coupling	11
Series SCL - with torsionally rigid shaft coupling	12
Proximity switch for Ratcheting SIKUMAT® with screw faces	13
Ratcheting SIKUMAT® SG ... with balls	14
Series SG - Basic version with flange connection	16
Series SGR - with short hub and integral needle bearing	17
Series SGG - with long hub	18
Series SGE - with flexible shaft coupling	19
Ratcheting SIKUMAT® ST ... – Backlash free with balls	20
Series ST - Basic version with flange connection	22
Series STG - with long hub	23
Series STE - with flexible shaft coupling	24
Series STL - with torsionally rigid shaft coupling	25
Synchronous Ratcheting SIKUMAT® SN ... with single rollers	26
Series SN - Basic version with flange connection	28
Series SNR - with short hub and integral needle bearing	29
Series SNG - with long hub	30
Series SNE - with flexible shaft coupling	31
Synchronous Ratcheting SIKUMAT® SA ... with double rollers	32
Series SA - Basic version with flange connection	34
Series SAG - with long hub	35
Series SAE - with flexible shaft coupling	36
Series SAL - with torsionally rigid shaft coupling	37
Synchronous Ratcheting SIKUMAT® SU ... – Backlash free with balls	38
Series SU - Basic version with flange connection	40
Series SUG - with long hub	41
Series SUE - with flexible shaft coupling	42
Series SUL - with torsionally rigid shaft coupling	43

SIKUMAT®-Torque Limiters	Page
Disengaging SIKUMAT® SR ... with single rollers	44
Series SR - Basic version with flange connection	46
Series SRR - with short hub and integral needle bearing	47
Series SRG - with long hub	48
Series SRE - with flexible shaft coupling	49
Synchronous Disengaging SIKUMAT® SB ... with double rollers	50
Series SB - Basic version with flange connection	52
Series SBG - with long hub	53
Series SBE - with flexible shaft coupling	54
Series SBL - with torsionally rigid shaft coupling	55
Non-disengaging SIKUMAT® SL ... with single rollers	56
Series SL - Basic version with flange connection	58
Series SLR - with short hub and integral needle bearings	59
Series SLG - with long hub	60
Series SLE - with flexible shaft coupling	61
SIKUMAT® Proximity Switch	
Non-contact SIKUMAT® Proximity Switch	62
Mechanical SIKUMAT® Proximity Switch	63
RIMOSTAT®-Torque Limiters	Page
RIMOSTAT®-Torque Limiters RS ...	64
Series RS	65
Series RSK - with chain wheel	66
Series RSC - with flexible chain coupling	67
Series RSHD - for heavy-duty applications	68
Belleville Spring Torque Limiter RT	
Series RT	70
RIMOSTAT®-Torque Limiters details	Page
Calculation of RIMOSTAT®-Torque Limiters	72
Force Limiters	Page
Force Limiters PA ...	74
Questionnaires	Page
Questionnaire for the selection of RINGSPANN Torque Limiters	78
Questionnaire for the selection of RINGSPANN Force Limiters	79

Issue 05/2023 • Technical details subject to change without notice.

SIKUMAT®

RIMOSTAT®

Registered Trademarks of RINGSPANN GmbH, Bad Homburg

Introduction Overload Clutches



The more comprehensive the automation of machines and installations, the safer their operational function needs to be. Blockages or overloads should never be cause for the destruction of operationally important components. Stoppages must be kept to a minimum so that the production process continues as quickly as possible and without costly repairs. After all, shorter downtimes mean higher productivity.

RINGSPANN Overload Clutches are mechanical safety devices which disconnect the output from the input when a preset limit value has been reached. Thus they protect against damage and stoppage times caused by overload.

For over 60 years RINGSPANN has manufactured Overload Clutches with an excellent track record in the most diverse applications.

Today RINGSPANN offers a comprehensive range of positive and friction Overload Clutches.

RINGSPANN supplies not only Overload Clutches but can also offer comprehensive advice and service. RINGSPANN provides the security you need.

Torque Limiters

Positive SIKUMAT® Torque Limiters are used as precision safety devices in installations and machines. The unsurpassed variety of working principles offer optimal solutions to every type of application:

- SIKUMAT® with screw faces for particularly heavy-duty operating conditions,
- SIKUMAT® with double rollers for high consistency of the limit torque over the duration of the operating period,
- SIKUMAT® with balls for very high response accuracy as well as for backlash free transmission of torque and
- SIKUMAT® with single rollers for universal application conditions.

Friction Torque Limiters

Friction Torque Limiters are available in two designs:

- RIMOSTAT® Torque Limiters for high torque consistency even during frequent slipping and
- Belleville Spring Torque Limiters for particularly cost effective solutions.

Force Limiters

RINGSPANN has designed a series of Force Limiters, outstanding in that forces up to a certain size can be transmitted in both directions completely free of play and rigid. On exceeding the pre-set disengaging force the power of the force is interrupted and the output part is no longer driven. After the overload has been cleared the driving part and the driven part are aligned towards each other and the Force Limiter re-engages automatically.

The Force Limiter can be fitted with non-contact proximity switch to give early warning of reaching a certain force, or disengaging signal.



SIKUMAT® SC ...



SIKUMAT® SG ...



SIKUMAT® ST ...



SIKUMAT® SN ...



SIKUMAT® SA ...



SIKUMAT® SU ...



SIKUMAT® SR ...

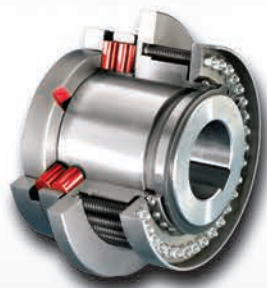

SIKUMAT® SB ...



SIKUMAT® SL ...

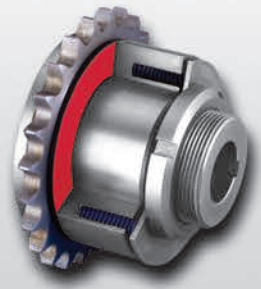

RIMOSTAT® RS ...



RIMOSTAT® RSHD



RIMOSTAT® RT

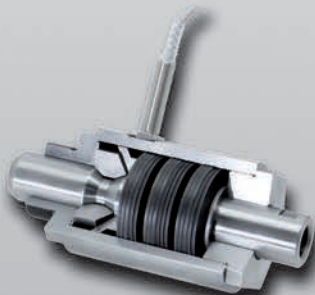













Force Limiters PA ...

Overview Overload Clutches

	Overload Clutches	Torque limiting by				Re-engagement			Backlash free	Consistency of torque limiting over operating period				
		Ratcheting	Dis-engaging	None*	Slipping	Auto-matic	Auto. synchron. after 360°	Manually		Manually synchron. after 360°	very high	high	medium	low
Positive Torque Limiters	SIKUMAT® SC ... with screw faces													
	SIKUMAT® SG ... with balls													
	SIKUMAT® ST ... Backlash free with balls													
	SIKUMAT® SN ... with single rollers													
	SIKUMAT® SA ... with double rollers													
	SIKUMAT® SU ... Backlash free with balls													
	SIKUMAT® SR ... with single rollers													
	SIKUMAT® SB ... with double rollers													
	SIKUMAT® SL ... with single rollers													
Friction Torque Limiters	RIMOSTAT® RS ... with coil springs													
	RIMOSTAT® RSHD													
	Belleville Spring Torque Limiters RT with belleville springs													
	Overload Clutches	Forces limiting by				Re-engagement			Backlash free	Consistency of force limiting over operating period				
		Ratcheting	Dis-engaging	None	Slipping	Auto-matic		Manually			very high	high	medium	low
Force Limiters	Force Limiter PA ...						/		/					

*When the preset limit torque has been reached, a limit sensor indicates the overload. There is no interruption of the torque transmission.

Adjustable limit torque or slipping torque [Nm]					Shaft ø max. [mm]	Speed range [min ⁻¹]			Robustness			Page
10	100	1 000	10 000	100 000		1 000	10 000	100 000	high	medium	low	
6 - 335					45	1 500						8
2,5 - 2 000					65	3 300						14
5 - 740					60	4 000						20
5 - 1 800					65	1 000						26
7 - 10 000					125	1 500						32
5 - 740					60	4 000						38
5 - 1 800					65	5 000						44
8 - 10 000					125	6 000						50
5 - 1 800					65	4 000						56
2 - 6 000					115	13 000						64
600 - 68 000					300	2 700						68
0,5 - 10 000					120	1 500						70
Disengaging force [N]					Shaft ø max. [mm]				Robustness			Page
1 000	10 000	100 000	1 000 000	10 000 000		1 000	10 000	100 000	high	medium	low	
3 600 - 140 000					75	/	/	/				74

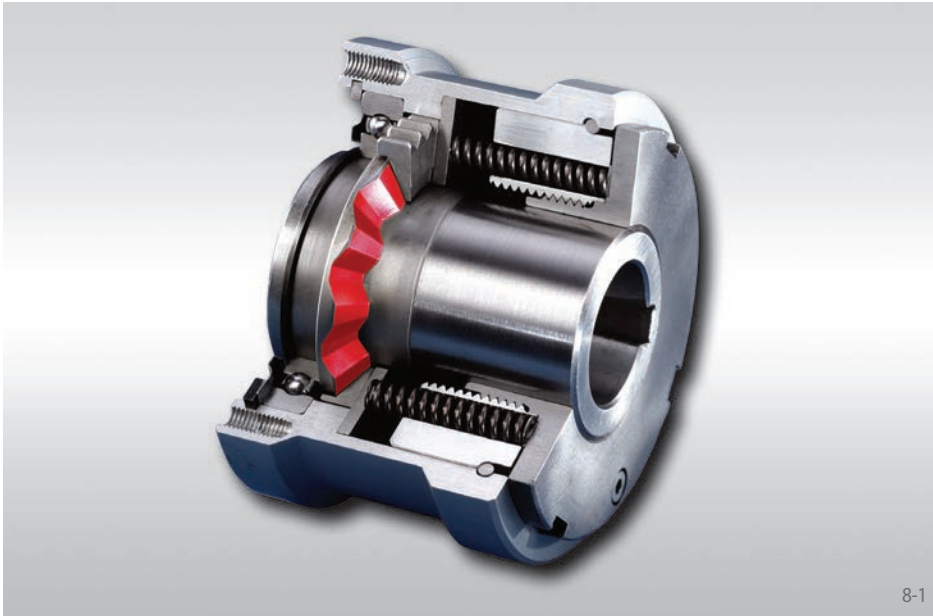

8-1

Advantages

- Excellent robustness through surface contact during the disengaging process – therefore maximum life
- Fully enclosed with integral bearing – therefore maintenance-free
- Adjustment of limit torque setting according to the number of active springs – not through modification of spring pressure

The Screw Face Principle

Torque transmission is effected through screw-shaped radial serrations in the input and output part, which are pressed together by spring force. Like the thread sides of a screw have edge contact with the nut during turning, so the toothed flanks of the SIKUMAT® retain their surface contact even during the torque disengaging process. This characteristic gives the SIKUMAT® an extremely high resistance against wear and therefore a long operating life.

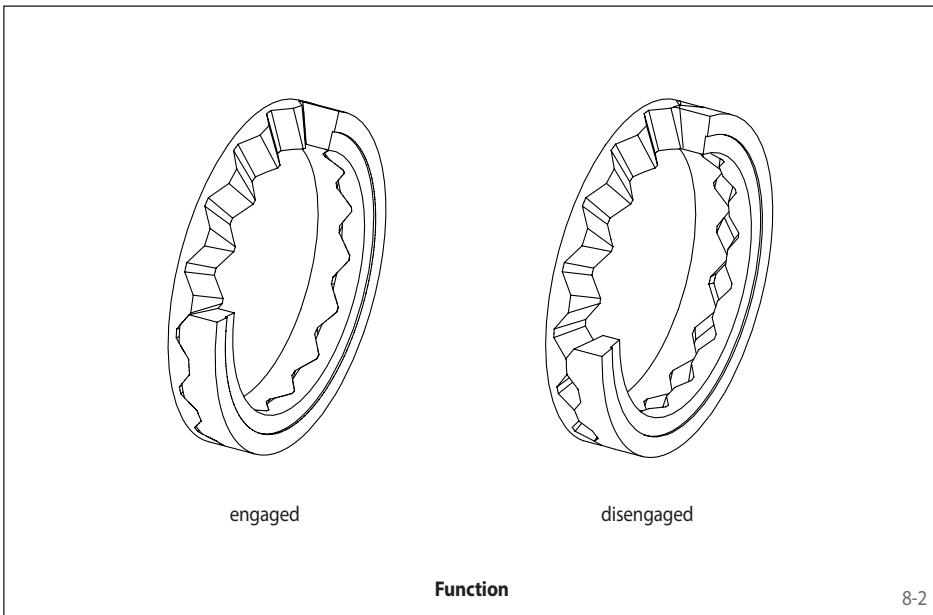

Function

8-2

Function

- When the preset limit torque has been reached the SIKUMAT® ratchets.
- After elimination of the overload the SIKUMAT® re-engages automatically.
- The overload can be indicated by the special proximity switch for the ratcheting SIKUMAT® with screw faces, thus either causing the drive to be switched off instantly or another control function to be activated.

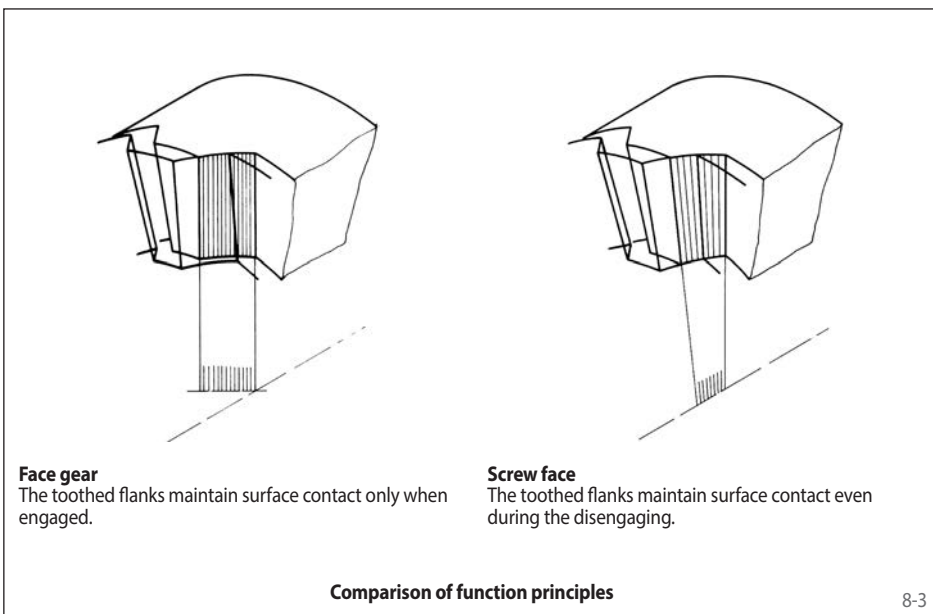

Face gear
The toothed flanks maintain surface contact only when engaged.

Screw face
The toothed flanks maintain surface contact even during the disengaging.

Comparison of function principles

8-3

Types

Series SC - Basic version with flange connection

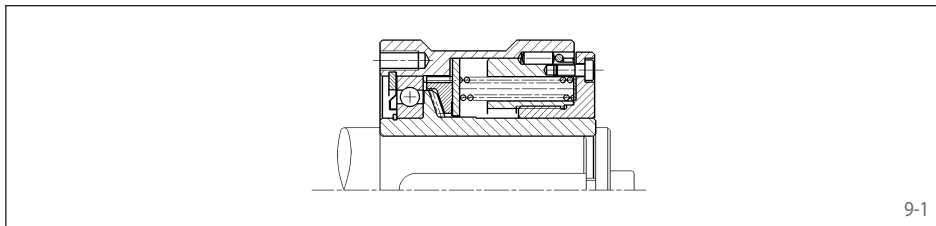

For attaching chain wheels, belt pulleys, gear wheels etc. Bearing of attached component on the shaft to be provided by the customer.

Page 10

Series SCE - with flexible shaft coupling

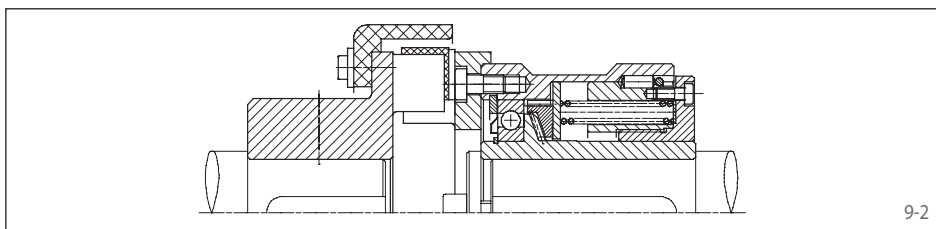

For flexible connection of two shafts. The flexible elements are oil-proof.

Page 11

Series SCL - with torsionally rigid shaft coupling

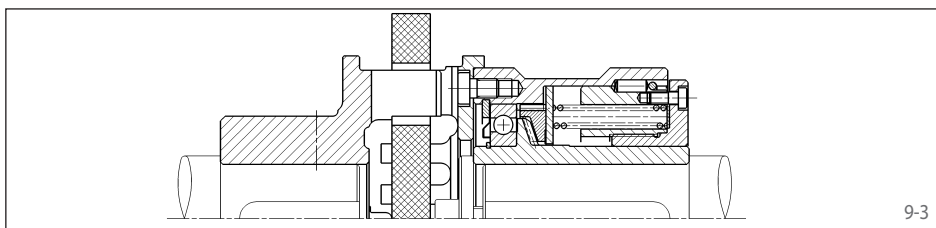

For torsionally rigid connection of two shafts. Possibility to compensate for large radial and angular displacements.

Page 12

Notes

Torque setting

Normally the limit torque is set at the factory. Setting or modification of the limit torque can be carried out by the customer but no unauthorised adjustment should be made by the machine operator. See operating instructions for further details.

Proximity switch

The proximity switch for the ratcheting SIKUMAT® with screw faces indicates overload by non-contact means with an inductive proximity switch. See page 13 for details.

with screw faces

Basic version with flange connection

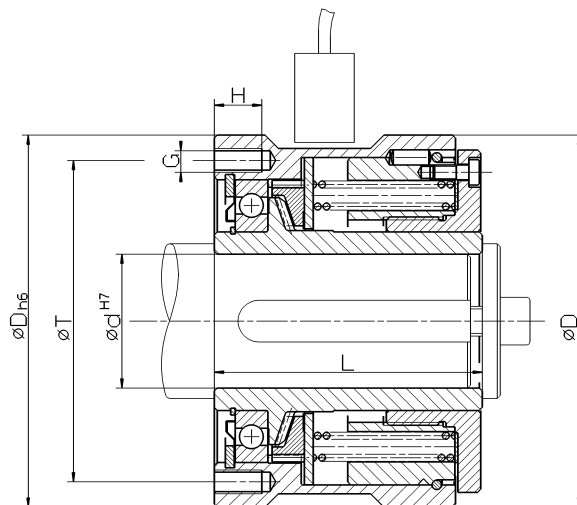

Z = number of tapped holes G on pitch circle T · Installation must be shut down as soon as torque limiter responds

10-1

Technical Data

Type	Art.-No.	Torque type 1			Torque type 2		
		Limit torque Nm	max. speed min ⁻¹	End number	Limit torque Nm	max. speed min ⁻¹	End number
SC 35.x	4472-004xxx	15 - 85	1 500	000	6 - 38	1 500	100
SC 45.x	4472-005xxx	20 - 125	1 500	000	9 - 55	1 500	100
SC 60.x	4472-006xxx	45 - 335	1 500	000	14 - 100	1 500	100

Dimensions

Type	Art.-No.	Bore d			D	G	H	L	T	Z	Engage-ment travel mm
		min. mm	max. ¹⁾ mm	max. ²⁾ mm							
SC 35.x	4472-004xxx	7	22	25	82	M 5	10	56	70	6	1,6
SC 45.x	4472-005xxx	9	30	32	100	M 6	12	71	90	6	2,0
SC 60.x	4472-006xxx	14	42	45	125	M 8	16	90	108	6	2,5

¹⁾ Max. bore diameter for keyways as per DIN 6885, p. 1

²⁾ Max. bore diameter for keyways as per DIN 6885, p. 3

Tolerance of keyway width P9

Example for Ordering

Type	Art.-No.	Preset limit torque	Bore d	with proximity switch
SC 35. 2	4472-004 100	7 Nm	12 mm	See page 13

└─┬─┘
Torque type

└─┬─┘
End number

with screw faces
with flexible shaft coupling

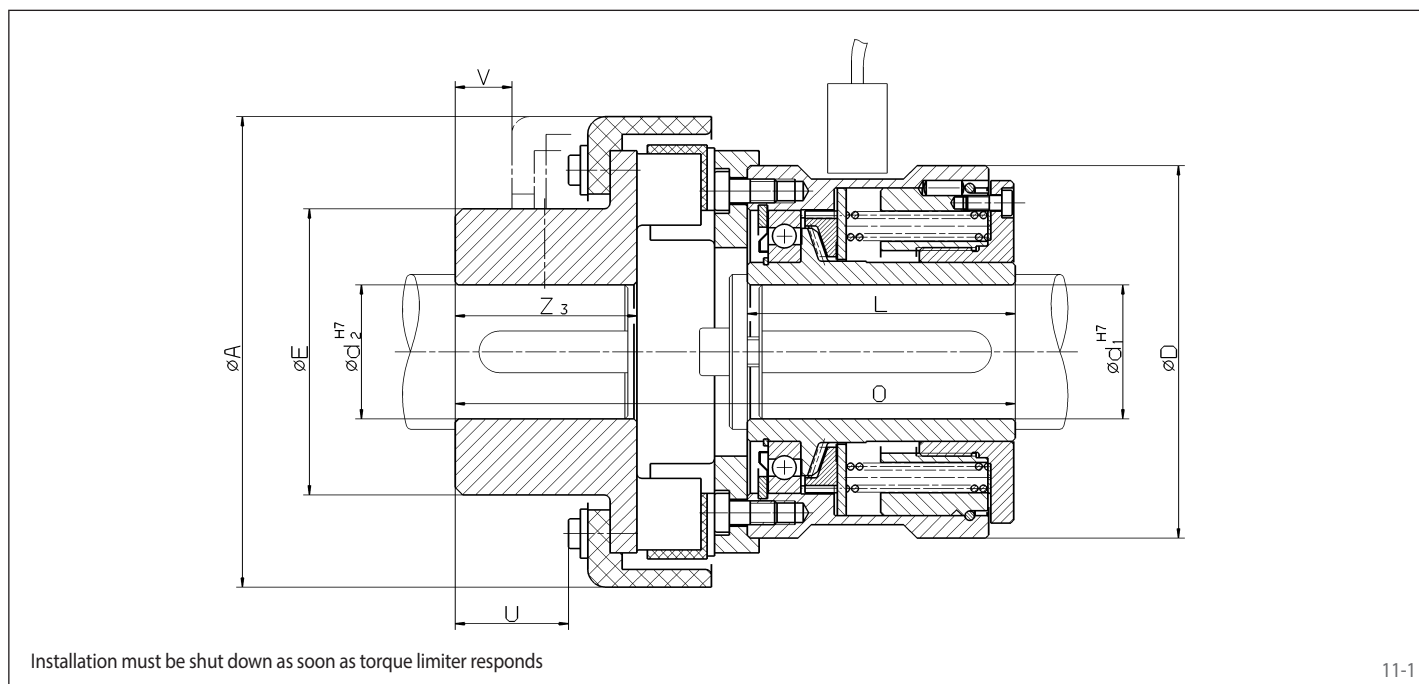

11-1

Technical Data

Type	Art.-No.	Torque type 1			Torque type 2		
		Limit torque Nm	max. speed min^{-1}	End number	Limit torque Nm	max. speed min^{-1}	End number
SCE 35.x	4472-604xxx	15 - 85	1 500	000	6 - 38	1 500	100
SCE 45.x	4472-605xxx	20 - 125	1 500	000	9 - 55	1 500	100
SCE 60.x	4472-606xxx	45 - 335	1 500	000	14 - 100	1 500	100

Dimensions

Type	Art.-No.	Bore d_1			Bore d_2		A	D	E	L	O	U	V	Z_3	Engage-ment travel
		min. mm	max. ¹⁾ mm	max. ²⁾ mm	min. mm	max. ¹⁾ mm									
SCE 35.x	4472-604xxx	7	22	25	10	45	114	82	72	56	131	28	19	48	1,6
SCE 45.x	4472-605xxx	9	30	32	10	50	127	100	78	71	151	31	20	52	2,0
SCE 60.x	4472-606xxx	14	42	45	20	60	158	125	96	90	188	39	21	61	2,5

¹⁾ Max. bore diameter for keyways as per DIN 6885, p. 1

²⁾ Max. bore diameter for keyways as per DIN 6885, p. 3

Tolerance of keyway width P9

Example for Ordering

Type	Art.-No.	Preset limit torque	Bore d_1	Bore d_2	with proximity switch
SCE 35. 2	4472-604 100	7 Nm	12 mm	15 mm	See page 13

Torque type

End number

with screw faces

with torsionally rigid shaft coupling

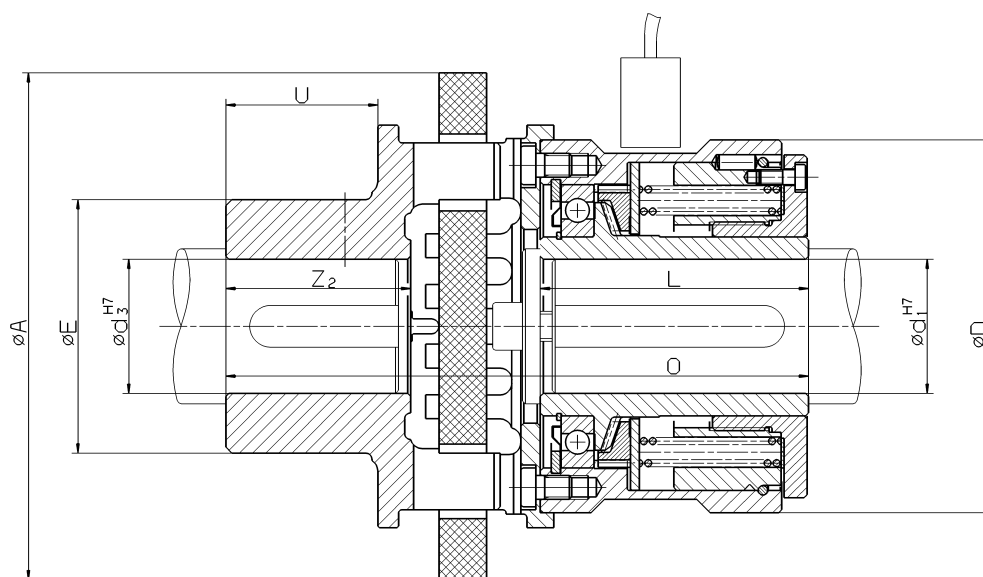

Installation must be shut down as soon as torque limiter responds

12-1

Technical Data

Type	Art.-No.	Torque type 1			Torque type 2		
		Limit torque Nm	max. speed min ⁻¹	End number	Limit torque Nm	max. speed min ⁻¹	End number
SCL 35.x	4472-404xxx	15 - 85	1 500	000	6 - 38	1 500	100
SCL 45.x	4472-405xxx	20 - 125	1 500	000	9 - 55	1 500	100
SCL 60.x	4472-406xxx	45 - 335	1 500	000	14 - 100	1 500	100

Dimensions

Type	Art.-No.	Bore d ₁			Bore d ₃		A	D	E	L	O	U	Z ₂	Engage-ment travel
		min. mm	max. ¹⁾ mm	max. ²⁾ mm	min. mm	max. ¹⁾ mm								
SCL 35.x	4472-404xxx	7	22	25	16	35	110	82	53	56	133	33	42	1,6
SCL 45.x	4472-405xxx	9	30	32	20	42	135	100	66	71	162	41	53	2,0
SCL 60.x	4472-406xxx	14	42	45	30	50	160	125	85	90	196	51	62	2,5

¹⁾ Max. bore diameter for keyways as per DIN 6885, p. 1

²⁾ Max. bore diameter for keyways as per DIN 6885, p. 3

Tolerance of keyway width P9

Example for Ordering

Type	Art.-No.	Preset limit torque	Bore d ₁	Bore d ₃	with proximity switch
SCL 35. 2	4472-404 100	7 Nm	12 mm	20 mm	See page 13

Torque type

End number

Proximity switch

for Ratcheting SIKUMAT® with screw faces

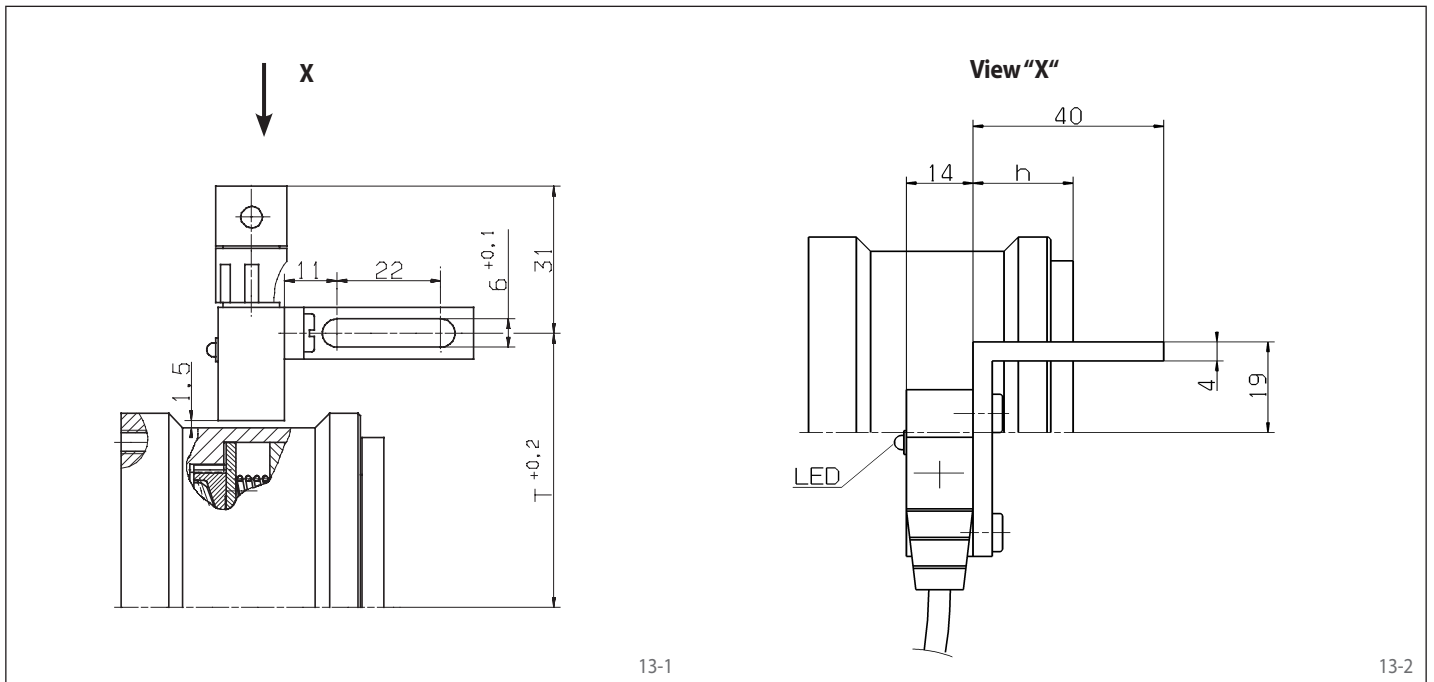

Type	Art.-No.
Proximity switch with plug connection	3504-000097-B024VG
Attaching plug, 90°, incl. 2 m PVC cable	2504-000001-A00002

Size	T mm	h mm
35	57,5	21
45	65,0	32
60	77,5	47

Effect

The proximity switch's response to an overload is to react on the switching disc located internally. During normal operation the proximity switch is closed, the yellow LED is illuminated. The switching disc moves as the preset limit torque is reached. The proximity switch opens and the yellow LED goes out. A speed-dependent switching sequence is triggered at the output end of the limit sensor.

Technical Data

Operating voltage:	24 V DC ±20%
Output:	PNP-Transistor
Max. switching current:	200 mA
Internal power consumption:	10 mA
Protection type:	IP 67
Ambient temperature:	-25° ... +75° C
Dimensions (H x L x W):	23 x 35 x 14 mm

Notes

The proximity switch is supplied with an aluminum support bracket which is fastened with 2 screws M 6 according to the drawing. The fastening must be non-oscillating. Once installed, the torque limiter's maximum permissible axial movement towards the proximity switch is 0,2 mm.

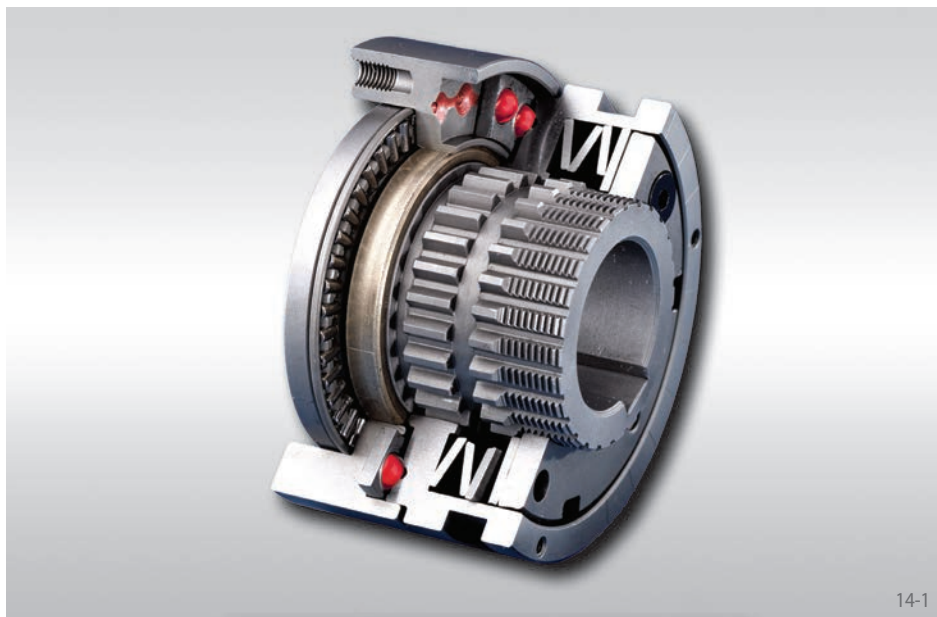

14-1

Advantages

- Very high response accuracy through the ball principle
- Integrated fixed bearing
- Keyway in connecting flange for maximum load capacity
- Calibrated micro adjustment of torque setting possible, even post-installation
- Cost effective

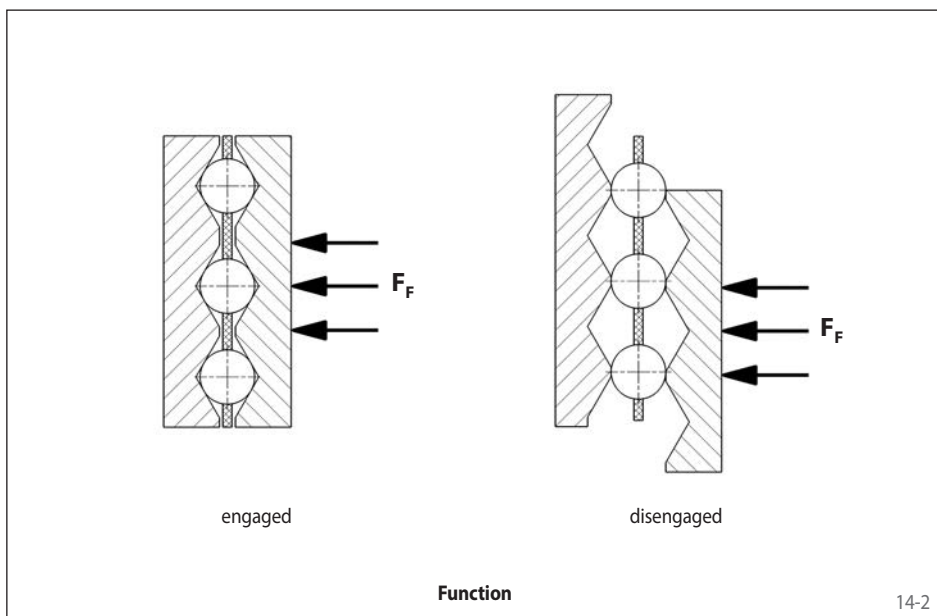

14-2

The Ball Principle

The torque is transmitted via balls which are pressed into detents via Belleville springs. When the preset limit torque has been reached the balls rise out of their seatings and slot into the nearest respective detent – until the overload has been eliminated. This characteristic, together with the special geometry of the detent gives the SIKUMAT® a very high response accuracy.

Function

- When the preset limit torque has been reached the SIKUMAT® ratchets.
- Automatic re-engagement of the SIKUMAT® after the overload has been eliminated.
- The overload can be indicated by a proximity switch. This means that the drive can be switched off immediately or another control function can be activated.

Types

Series SG - Basic version with flange connection

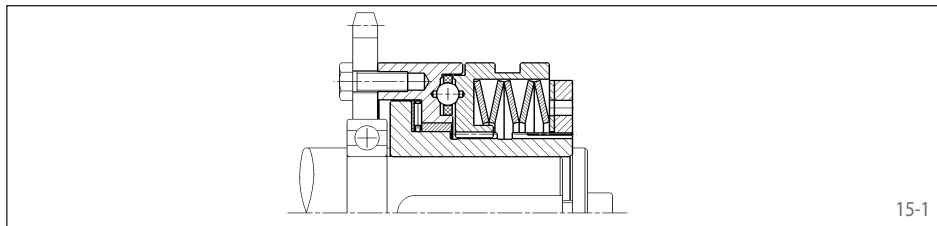

For attaching chain wheels, belt pulleys, gear wheels etc. Bearing of attached component on the shaft to be provided by the customer.

Page 16

Series SGR - with short hub and integral needle bearing

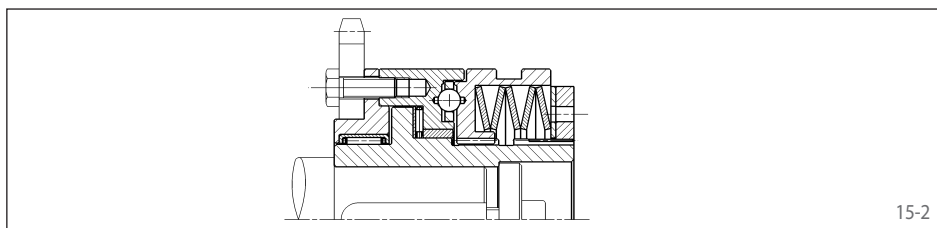

With short hub and needle bearing for narrow components to be connected

Page 17

Series SGG - with long hub

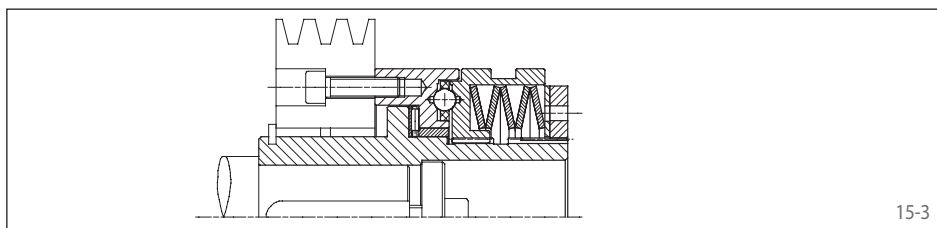

With long hub for wide components to be connected. Bearing of the attached component in the form of plain or needle bearing to be provided by the customer.

Page 18

Series SGE - with flexible shaft coupling

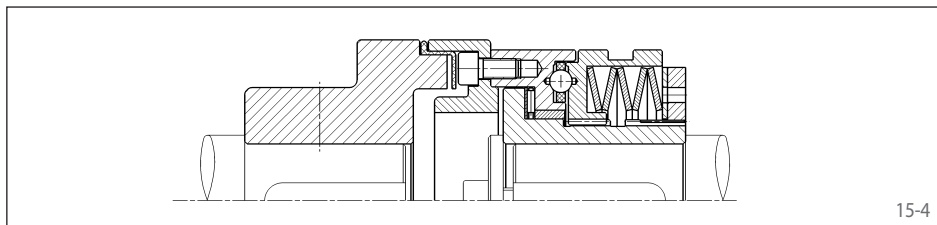

For flexible connection of two shafts. The flexible elements are oil-proof.

Page 19

Notes

Torque setting

The limit torque can be set at the factory on request. Setting or modification of the limit torque can also be carried out by the customer. See operating instructions for further details.

Proximity switch

The overload can be indicated by a non-contact or a mechanical proximity switch. Further details on pages 62 and 63.

with balls

Basic version with flange connection

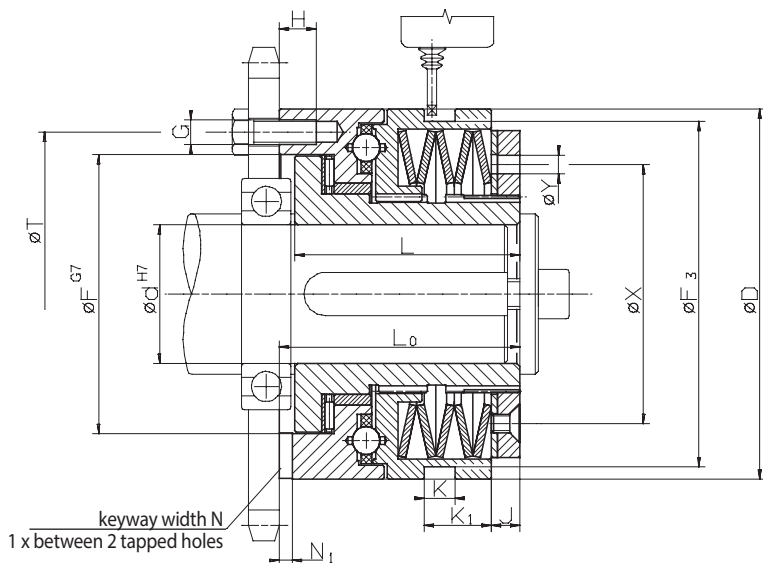

Z = number of tapped holes G on pitch circle T · Installation must be shut down as soon as torque limiter responds

16-1

Technical Data

Type	Art.-No.	Torque type 1			Torque type 2			Torque type 3			Torque type 4		
		Limit torque Nm	max. speed min ⁻¹	End number	Limit torque Nm	max. speed min ⁻¹	End number	Limit torque Nm	max. speed min ⁻¹	End number	Limit torque Nm	max. speed min ⁻¹	End number
SG 32.x	4478-020xxx	2,5 - 5	3 300	001	5 - 10	3 300	002	10 - 20	1 800	003	20 - 40	1 800	004
SG 40.x	4478-025xxx	6 - 12	2 900	001	12 - 25	2 900	002	25 - 55	1 450	003	55 - 100	1 450	004
SG 55.x	4478-035xxx	12 - 25	2 400	001	25 - 50	2 400	002	50 - 120	1 200	003	120 - 200	1 200	004
SG 65.x	4478-045xxx	25 - 50	2 000	001	50 - 100	2 000	002	100 - 250	1 000	003	200 - 480	1 000	004
SG 80.x	4478-055xxx	50 - 100	1 600	001	100 - 200	1 600	002	200 - 500	850	003	400 - 1 000	850	004
SG 90.x	4478-065xxx	85 - 250	1 400	001	230 - 600	1 400	002	300 - 1 000	700	003	600 - 2 000	700	004

Dimensions

Type	Art.-No.	Bore d		D	F	F ₃	G	H	J	K	K ₁	L	L ₀	N	N ₁	T	X	Y	Z	Engage-ment travel
		min. mm	max. mm																	
SG 32.x	4478-020xxx	7	20	55	41	50	M 5	6,5	3	9	13,5	34,5	38,5	6	3,1	48	38,5	5	6	1,4
SG 40.x	4478-025xxx	10	25	82	60	72,5	M 5	8	6	9	14,5	48	52	6	3,1	70	54	6	6	2,3
SG 55.x	4478-035xxx	14	35	100	78	90,5	M 6	10	5	9	15	56	61	8	3,6	89	70	6	6	2,4
SG 65.x	4478-045xxx	18	45	120	90,5	112	M 8	12	8,5	10	22,5	73	78	10	4,1	105	84	6	6	2,7
SG 80.x	4478-055xxx	24	55	146	105	140	M 10	15	11	9	25	93,5	100	12	4,1	125	108	10	6	3,7
SG 90.x	4478-065xxx	30	70 ¹⁾	176	120,5	170	M 12	17	12	9	30	107	113,5	14	4,6	155	129	10	6	4,6

Keyway as per DIN 6885, page 1 · Tolerance of keyway width JS9

¹⁾ Keyway as per DIN 6885, page 3 · Tolerance of keyway width JS9

Example for Ordering

Type	Art.-No.	Preset limit torque	Bore d	with proximity switch
SG 32. 2	4478-020 002	7 Nm	12 mm	See pages 62 and 63

└─┬─┘
Torque type

└─┬─┘
End number

with balls
with short hub and integral needle bearing

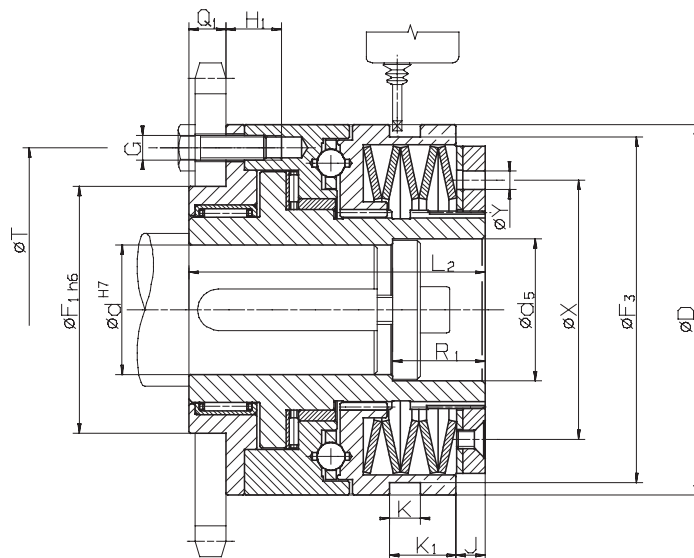

Z = number of tapped holes G on pitch circle T · Installation must be shut down as soon as torque limiter responds

17-1

Technical Data

Type	Art.-No.	Torque type 1			Torque type 2			Torque type 3			Torque type 4		
		Limit torque Nm	max. speed min ⁻¹	End number	Limit torque Nm	max. speed min ⁻¹	End number	Limit torque Nm	max. speed min ⁻¹	End number	Limit torque Nm	max. speed min ⁻¹	End number
SGR 32.x	4478-920xxx	2,5 - 5	3 300	001	5 - 10	3 300	002	10 - 20	1 800	003	20 - 40	1 800	004
SGR 40.x	4478-925xxx	6 - 12	2 900	001	12 - 25	2 900	002	25 - 55	1 450	003	55 - 100	1 450	004
SGR 55.x	4478-935xxx	12 - 25	2 400	001	25 - 50	2 400	002	50 - 120	1 200	003	120 - 200	1 200	004
SGR 65.x	4478-945xxx	25 - 50	2 000	001	50 - 100	2 000	002	100 - 250	1 000	003	200 - 480	1 000	004
SGR 80.x	4478-955xxx	50 - 100	1 600	001	100 - 200	1 600	002	200 - 500	850	003	400 - 1 000	850	004
SGR 90.x	4478-965xxx	85 - 250	1 400	001	230 - 600	1 400	002	300 - 1 000	700	003	600 - 2 000	700	004

Dimensions

Type	Art.-No.	Bore d		d ₅	D	F ₁	F ₃	G	H ₁	J	K	K ₁	L ₂	Q ₁	R ₁	T	X	Y	Z	Engage-ment travel
		min. mm	max. mm																	
SGR 32.x	4478-920xxx	7	20	21	55	38	50	M 5	11	3	9	13,5	51	8	15	48	38,5	5	6	1,4
SGR 40.x	4478-925xxx	10	25	26	82	50	72,5	M 5	16	6	9	14,5	70	10	20	70	54	6	6	2,3
SGR 55.x	4478-935xxx	14	35	36	100	60	90,5	M 6	15	5	9	15	78	12	25	89	70	6	6	2,4
SGR 65.x	4478-945xxx	18	45	46	120	80	112	M 8	18	8,5	10	22,5	96	12	30	105	84	6	6	2,7
SGR 80.x	4478-955xxx	24	55	56	146	100	140	M 10	23,5	11	9	25	124,5	16	30	125	108	10	6	3,7
SGR 90.x	4478-965xxx	30	70 ¹⁾	66	176	120	170	M 12	25,5	12	9	30	140	18	30	155	129	10	6	4,6

Keyway as per DIN 6885, page 1 · Tolerance of keyway width JS9

¹⁾ Keyway as per DIN 6885, page 3 · Tolerance of keyway width JS9

Example for Ordering

Type	Art.-No.	Preset limit torque	Bore d	with proximity switch
SGR 32. 2	4478-920 002	7 Nm	12 mm	See pages 62 and 63

└─┬─┘
Torque type

└─┬─┘
End number

with balls
with long hub

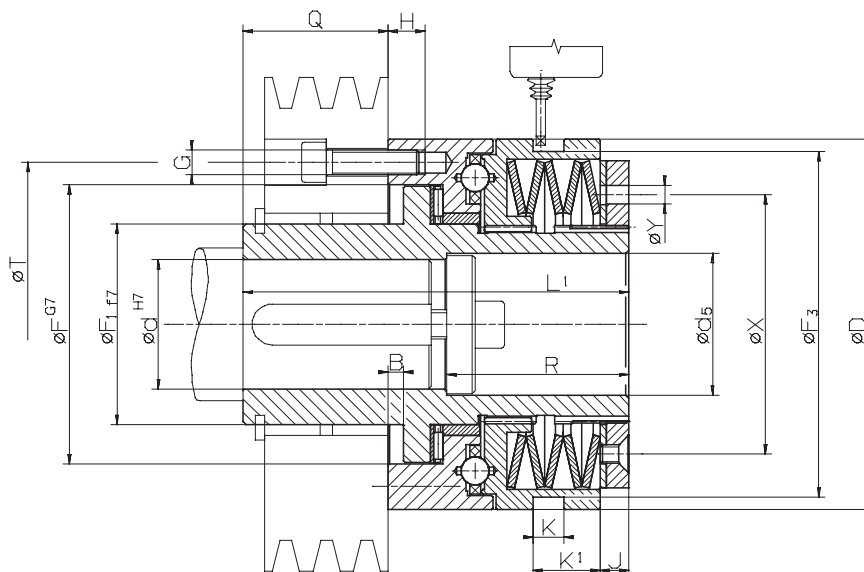

Z = number of tapped holes G on pitch circle T · Installation must be shut down as soon as torque limiter responds

18-1

Technical Data

Type	Art.-No.	Torque type 1			Torque type 2			Torque type 3			Torque type 4		
		Limit torque Nm	max. speed min ⁻¹	End number	Limit torque Nm	max. speed min ⁻¹	End number	Limit torque Nm	max. speed min ⁻¹	End number	Limit torque Nm	max. speed min ⁻¹	End number
SGG 32.x	4478-120xxx	2,5 - 5	3 300	001	5 - 10	3 300	002	10 - 20	1 800	003	20 - 40	1 800	004
SGG 40.x	4478-125xxx	6 - 12	2 900	001	12 - 25	2 900	002	25 - 55	1 450	003	55 - 100	1 450	004
SGG 55.x	4478-135xxx	12 - 25	2 400	001	25 - 50	2 400	002	50 - 120	1 200	003	120 - 200	1 200	004
SGG 65.x	4478-145xxx	25 - 50	2 000	001	50 - 100	2 000	002	100 - 250	1 000	003	200 - 480	1 000	004
SGG 80.x	4478-155xxx	50 - 100	1 600	001	100 - 200	1 600	002	200 - 500	850	003	400 - 1 000	850	004
SGG 90.x	4478-165xxx	85 - 250	1 400	001	230 - 600	1 400	002	300 - 1 000	700	003	600 - 2 000	700	004

Dimensions

Type	Art.-No.	Bore d		d ₅	B	D	F	F ₁	F ₃	G	H	J	K	K ₁	L ₁	Q	R	T	X	Y	Z	Engage-ment travel
		min. mm	max. mm																			
SGG 32.x	4478-120xxx	7	20	21	4	55	41	28	50	M 5	6,5	3	9	13,5	66	27,5	25,5	48	38,5	5	6	1,4
SGG 40.x	4478-125xxx	10	25	26	4	82	60	38	72,5	M 5	8	6	9	14,5	85	33	35	70	54	6	6	2,3
SGG 55.x	4478-135xxx	14	35	36	5	100	78	52	90,5	M 6	10	5	9	15	100	39	45	89	70	6	6	2,4
SGG 65.x	4478-145xxx	18	45	46	5	120	90,5	65	112	M 8	12	8,5	10	22,5	125	47	59	105	84	6	6	2,7
SGG 80.x	4478-155xxx	24	55	56	6,5	146	105	78	140	M 10	15	11	9	25	152,5	52,5	60	125	108	10	6	3,7
SGG 90.x	4478-165xxx	30	70 ¹⁾	66	6,5	176	120,5	90	170	M 12	17	12	9	30	171	57,5	60	155	129	10	6	4,6

Keyway as per DIN 6885, page 1 · Tolerance of keyway width JS9

¹⁾ Keyway as per DIN 6885, page 3 · Tolerance of keyway width JS9

Example for Ordering

Type	Art.-No.	Preset limit torque	Bore d	with proximity switch
SGG 32. 2	4478-120 002	7 Nm	12 mm	See pages 62 and 63

└─┬─┘
Torque type

└─┬─┘
End number

with balls
with flexible shaft coupling

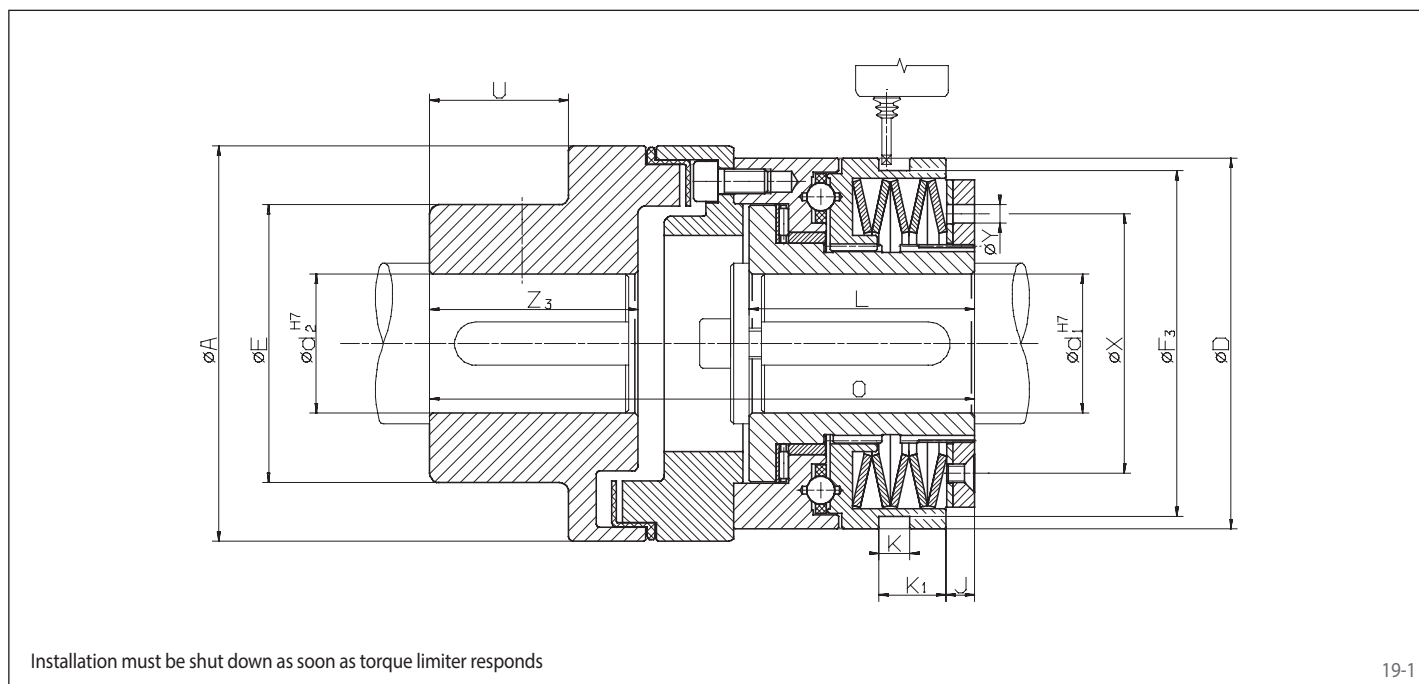

19-1

Technical Data

Type	Art.-No.	Torque type 1			Torque type 2			Torque type 3			Torque type 4		
		Limit torque Nm	max. speed min ⁻¹	End number	Limit torque Nm	max. speed min ⁻¹	End number	Limit torque Nm	max. speed min ⁻¹	End number	Limit torque Nm	max. speed min ⁻¹	End number
SGE 32.x	4478-620xxx	2,5 - 5	3 300	001	5 - 10	3 300	002	10 - 20	1 800	003	20 - 40	1 800	004
SGE 40.x	4478-625xxx	6 - 12	2 900	001	12 - 25	2 900	002	25 - 55	1 450	003	55 - 100	1 450	004
SGE 55.x	4478-635xxx	12 - 25	2 400	001	25 - 50	2 400	002	50 - 120	1 200	003	120 - 200	1 200	004
SGE 65.x	4478-645xxx	25 - 50	2 000	001	50 - 100	2 000	002	100 - 250	1 000	003	200 - 480	1 000	004
SGE 80.x	4478-655xxx	50 - 100	1 600	001	100 - 200	1 600	002	200 - 500	850	003	400 - 1 000	850	004
SGE 90.x	4478-665xxx	85 - 250	1 400	001	230 - 600	1 400	002	300 - 1 000	700	003	600 - 2 000	700	004

Dimensions

Type	Art.-No.	Bore d ₁		d ₂ max. mm	A mm	E mm	D mm	F ₃ mm	J mm	K mm	K ₁ mm	L mm	O mm	U mm	X mm	Y mm	Z ₃ mm	Engage- ment travel mm
		min. mm	max. mm															
SGE 32.x	4478-620xxx	7	20	30	67	46	55	50	3	9	13,5	35	86	15	38,5	5	28	1,4
SGE 40.x	4478-625xxx	10	25	50	112	79	82	72,5	6	9	14,5	48	137,5	38	54	6	58	2,3
SGE 55.x	4478-635xxx	14	35	50	112	79	100	90,5	5	9	15	56	147	38	70	6	58	2,4
SGE 65.x	4478-645xxx	18	45	60	128	90	120	112	8,5	10	22,5	72	176,5	45	84	6	67	2,7
SGE 80.x	4478-655xxx	24	55	60	148	90	146	140	11	9	25	93,5	211,5	45	108	10	67	3,7
SGE 90.x	4478-665xxx	30	70 ¹⁾	70	177	107	176	170	12	9	30	107	242,5	52	129	10	77	4,6
SGE 90.4	4478-665xxx	30	70 ¹⁾	90	198	140	176	170	12	9	30	107	272	62	129	10	97	4,6

Keyway as per DIN 6885, page 1 - Tolerance of keyway width JS9

¹⁾ Keyway as per DIN 6885, page 3 - Tolerance of keyway width JS9

Example for Ordering

Type	Art.-No.	Preset limit torque	Bore d ₁	Bore d ₂	with proximity switch
SGE 32. 2	4478-620 002	7 Nm	12 mm	25 mm	See pages 62 and 63

└
Torque type

└
End number



Advantages

- Backlash free in both directions of rotation
- Compact design
- Integral ball bearing for supporting the component to be connected
- Very high response accuracy through the ball principle
- Simple and backlash free fastening onto shaft with integral cone clamping element
- Calibrated micro adjustment of torque setting possible, even post-installation

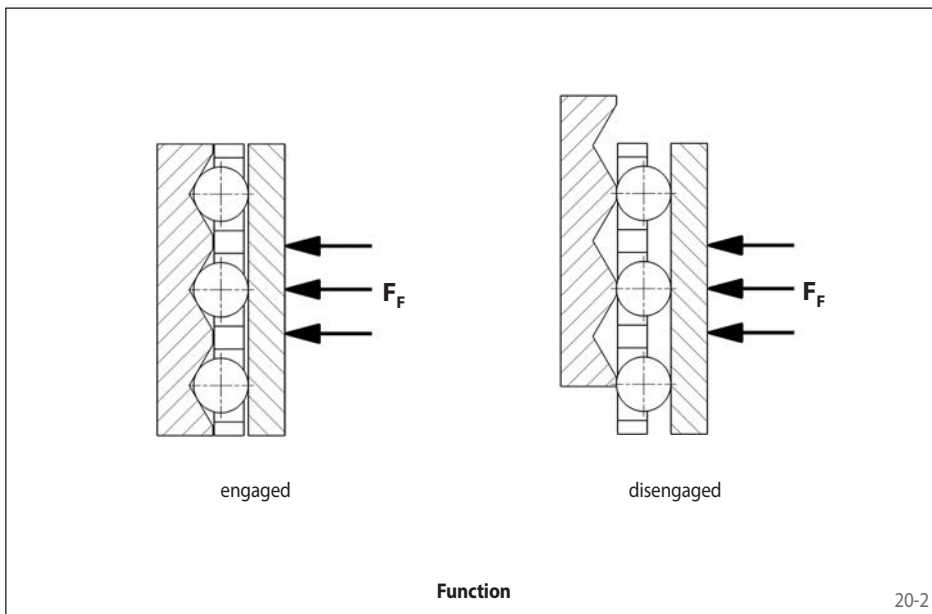

The Ball Principle - Backlash free

The torque is transmitted via balls which are pressed into V-shaped grooves. The grooves are arranged axially on the output side and radially on the input side, which means that torque can be transmitted backlash free in both directions of rotation. As the preset limit torque is reached, the balls rise out of the axial grooves and ratchet into the respective next axial groove – until the overload has been eliminated. The negative characteristic disc springs give extremely fast, accurate and consistent overload protection.

Function

- When the preset limit torque has been reached the SIKUMAT® ratchets through.
- Automatic re-engagement of the SIKUMAT® after the overload has been eliminated.
- The overload can be indicated by a proximity switch. This means that the drive can be switched off immediately or another control function can be activated.

Types

Series ST - Basic version with flange connection

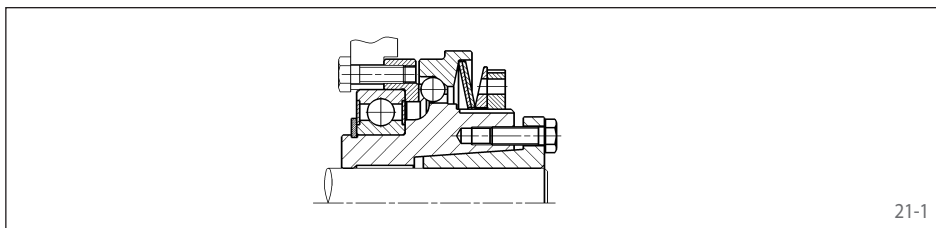

For attaching chain wheels, belt pulleys, gear wheels etc. Support of the component to be connected directly on the integral ball bearing.

Page 22

Series STG - with long hub

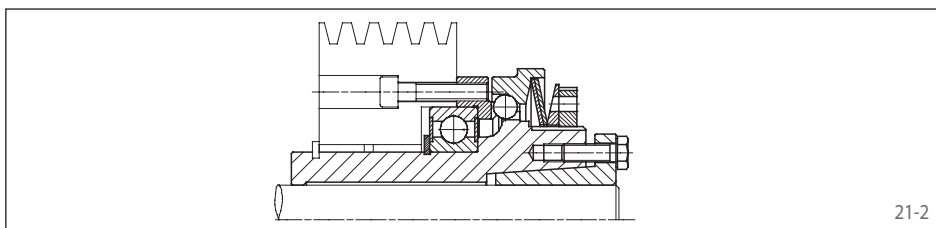

With long hub for wide components to be connected. Support of the component to be connected directly on the integral ball bearing; additional radial bearing to be provided by the customer.

Page 23

Series STE - with flexible shaft coupling

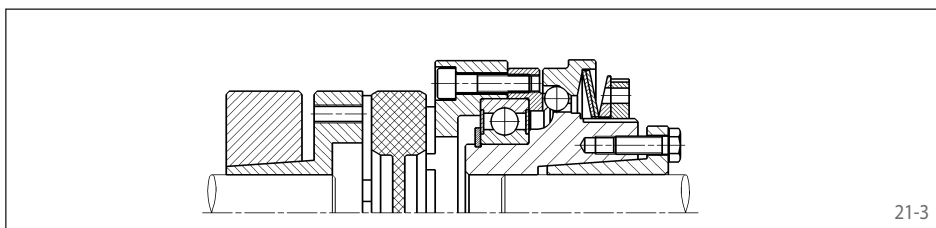

For flexible connection of two shafts.

Page 24

Series STL - with torsionally rigid shaft coupling

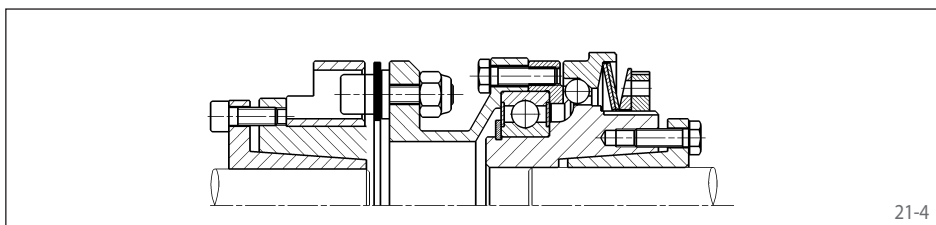

For rigid connection of two shafts.

Page 25

Notes

Torque setting

The limit torque can be set at the factory on request. Setting or modification of the limit torque can also be carried out by the customer. See operating instructions for further details.

Proximity switch

The overload can be indicated by a non-contact or a mechanical proximity switch. Further details on pages 62 and 63.

with balls

Basic version with flange connection

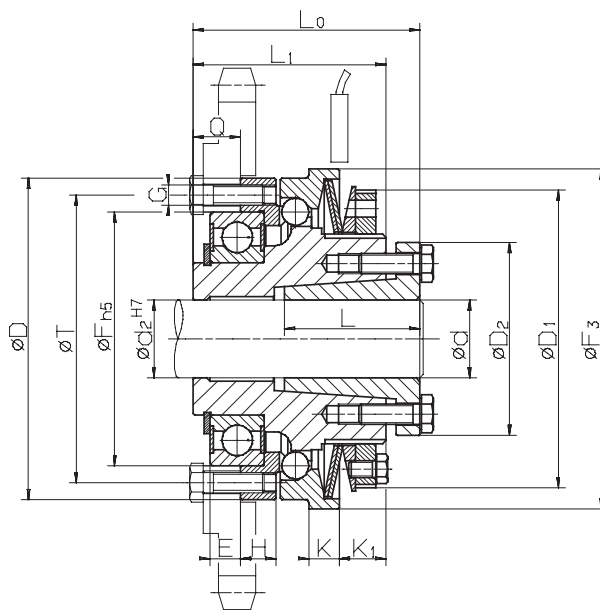

Z = number of tapped holes G on pitch circle T · Installation must be shut down as soon as torque limiter responds

22-1

Technical Data

Type	Art.-No.	Torque type 1			Torque type 2			Torque type 3		
		Limit torque Nm	max. speed min ⁻¹	End number	Limit torque Nm	max. speed min ⁻¹	End number	Limit torque Nm	max. speed min ⁻¹	End number
ST 30.x	4479-025xxx	5 - 14	4 000	001	10 - 28	4 000	002	20 - 60	4 000	003
ST 40.x	4479-030xxx	9 - 27	3 000	001	18 - 54	3 000	002	38 - 115	3 000	003
ST 45.x	4479-040xxx	19 - 60	2 500	001	38 - 125	2 500	002	70 - 255	2 500	003
ST 55.x	4479-050xxx	35 - 110	2 000	001	80 - 220	2 000	002	160 - 440	2 000	003
ST 65.x	4479-060xxx	80 - 185	1 200	001	160 - 370	1 200	002	320 - 740	1 200	003

Dimensions

Type	Art.-No.	Bore d*		D	D ₁	D ₂	E	F	F ₃	G	H	K	K ₁	L	L ₀	L ₁	Q	T	Z	Engage-ment travel mm
		min. mm	max. mm																	
ST 30.x	4479-025xxx	10	20	65	63	40,5	5	47	70	M 4	7,5	7	12	26	47	40	8	56	8	1,2
ST 30.x	4479-025xxx	19	25	65	63	42	5	47	70	M 4	7,5	7	12	26	47	40	8	56	8	1,2
ST 40.x	4479-030xxx	15	30	80	77	57	7	62	85	M 5	8	8	12	31	56	46	11	71	8	1,5
ST 45.x	4479-040xxx	19	30	95	88	57	9	75	100	M 6	10,5	9	14	40	67	57	14	85	8	1,8
ST 45.x	4479-040xxx	32	40	95	88	64	9	75	100	M 6	10,5	9	14	31	67	57	14	85	8	1,8
ST 55.x	4479-050xxx	32	50	110	100	73,5	10	90	115	M 6	12	10	16	29	73	63	16	100	8	2,0
ST 65.x	4479-060xxx	32	50	130	122	73,5	10	100	135	M 8	12	12	21	29	85	75	18	116	8	2,2
ST 65.x	4479-060xxx	55	60	130	122	89	10	100	135	M 8	12	12	21	45,5	86	75	18	116	8	2,2

Hub bore diameter d₂ is equal to the selected diameter d and serves as an additional centering guide.

*Available bore diameters d: 10, 11, 12, 14, 15, 16, 18, 19, 20, 22, 24, 25, 28, 30, 32, 35, 38, 40, 42, 45, 48, 50, 55 and 60 mm.

Example for Ordering

Type	Art.-No.	Preset limit torque	Bore d	with proximity switch
ST 40. 2	4479-030 002	25 Nm	20 mm	See pages 62 and 63

Torque type

End number

with balls
with long hub

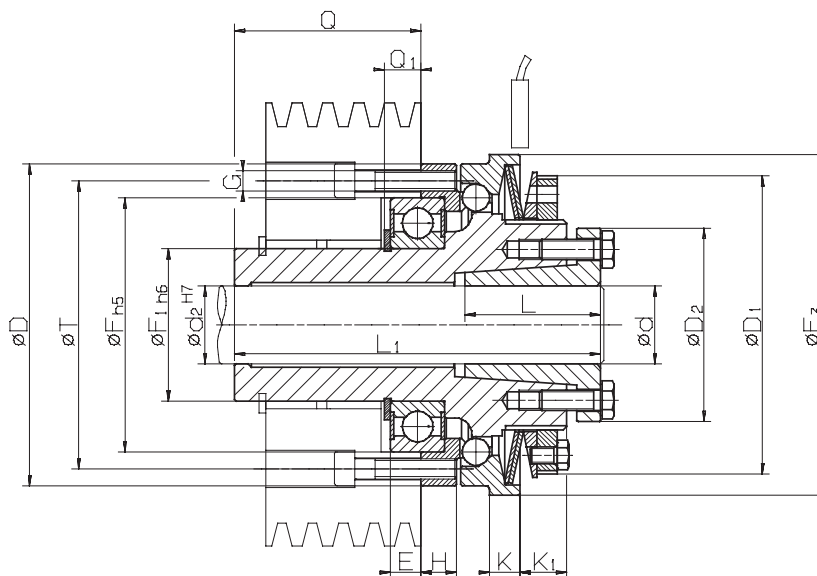

Z = number of tapped holes G on pitch circle T · Installation must be shut down as soon as torque limiter responds

23-1

Technical Data

Type	Art.-No.	Torque type 1			Torque type 2			Torque type 3		
		Limit torque Nm	max. speed min ⁻¹	End number	Limit torque Nm	max. speed min ⁻¹	End number	Limit torque Nm	max. speed min ⁻¹	End number
STG 30.x	4479-125xxx	5 - 14	4 000	001	10 - 28	4 000	002	20 - 60	4 000	003
STG 40.x	4479-130xxx	9 - 27	3 000	001	18 - 54	3 000	002	38 - 115	3 000	003
STG 45.x	4479-140xxx	19 - 60	2 500	001	38 - 125	2 500	002	70 - 255	2 500	003
STG 55.x	4479-150xxx	35 - 110	2 000	001	80 - 220	2 000	002	160 - 440	2 000	003
STG 65.x	4479-160xxx	80 - 185	1 200	001	160 - 370	1 200	002	320 - 740	1 200	003

Dimensions

Type	Art.-No.	Bore d*		D	D ₁	D ₂	E	F	F ₁	F ₃	G	H	K	K ₁	L	L ₁	Q	Q ₁	T	Z	Engage-ment travel mm
		min. mm	max. mm																		
STG 30.x	4479-125xxx	10	20	65	63	40,5	5	47	30	70	M 4	7,5	7	12	26	72	33	6,5	56	8	1,2
STG 30.x	4479-125xxx	19	25	65	63	42	5	47	30	70	M 4	7,5	7	12	26	72	33	6,5	56	8	1,2
STG 40.x	4479-130xxx	15	30	80	77	57	7	62	40	85	M 5	8	8	12	31	88	43	8,75	71	8	1,5
STG 45.x	4479-140xxx	19	30	95	88	57	9	75	45	100	M 6	10,5	9	14	40	108	55	11,5	85	8	1,8
STG 45.x	4479-140xxx	32	40	95	88	64	9	75	45	100	M 6	10,5	9	14	31	108	55	11,5	85	8	1,8
STG 55.x	4479-150xxx	32	50	110	100	73,5	10	90	55	115	M 6	12	10	16	29	124	67	13	100	8	2,0
STG 65.x	4479-160xxx	32	50	130	122	73,5	10	100	65	135	M 8	12	12	21	29	140	73	14	116	8	2,2
STG 65.x	4479-160xxx	55	60	130	122	89	10	100	65	135	M 8	12	12	21	45,5	141	73	14	116	8	2,2

Diameter d₂ at the end of the long hub is equal to the selected diameter d and serves as an additional centering.

*Available bore diameters d: 10, 11, 12, 14, 15, 16, 18, 19, 20, 22, 24, 25, 28, 30, 32, 35, 38, 40, 42, 45, 48, 50, 55 and 60 mm.

Example for Ordering

Type	Art.-No.	Preset limit torque	Bore d	with proximity switch
STG 65. 1	4479-160 001	90 Nm	60 mm	See pages 62 and 63

Torque type

End number

with balls
with flexible shaft coupling

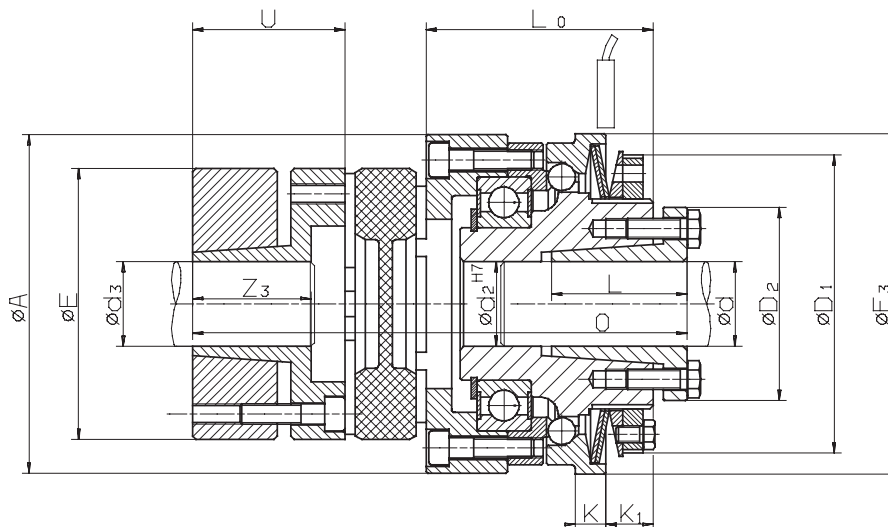

Installation must be shut down as soon as torque limiter responds

24-1

Technical Data

Type	Art.-No.	Torque type 1			Torque type 2			Torque type 3		
		Limit torque Nm	max. speed min ⁻¹	End number	Limit torque Nm	max. speed min ⁻¹	End number	Limit torque Nm	max. speed min ⁻¹	End number
STE 30.x	4479-625xxx	5 - 14	4 000	001	10 - 28	4 000	002	20 - 60	4 000	003
STE 40.x	4479-630xxx	9 - 27	3 000	001	18 - 54	3 000	002	38 - 115	3 000	003
STE 45.x	4479-640xxx	19 - 60	2 500	001	38 - 125	2 500	002	70 - 255	2 500	003
STE 55.x	4479-650xxx	35 - 110	2 000	001	80 - 220	2 000	002	160 - 440	2 000	003
STE 65.x	4479-660xxx	80 - 185	1 200	001	160 - 370	1 200	002	320 - 740	1 200	003

Dimensions

Type	Art.-No.	Bore d*		Bore d ₃ **		A	D ₁	D ₂	E	F ₃	K	K ₁	L	L ₀	O	U	Z ₃	Engage-ment travel
		min. mm	max. mm	mm	mm													
STE 30.x	4479-625xxx	10	20	15	28	70	63	40,5	55	70	7	12	26	47	102	30	30	1,2
STE 30.x	4479-625xxx	19	25	15	28	70	63	42	55	70	7	12	26	47	102	30	30	1,2
STE 40.x	4479-630xxx	15	30	15	38	85	77	57	65	85	8	12	31	54,5	119,5	35	35	1,5
STE 45.x	4479-640xxx	19	30	20	45	100	88	64	80	100	9	14	40	67	146	45	45	1,8
STE 45.x	4479-640xxx	32	40	20	45	100	88	64	80	100	9	14	31	67	146	45	45	1,8
STE 55.x	4479-650xxx	32	50	25	50	115	100	73,5	95	115	10	16	29	73	159	50	50	2,0
STE 65.x	4479-660xxx	32	50	30	55	135	122	73,5	105	135	12	21	29	87	182	56	56	2,2
STE 65.x	4479-660xxx	55	60	30	55	135	122	89	105	135	12	21	45,5	87	182	56	56	2,2

Hub bore diameter d₂ is equal to the selected diameter d and serves as an additional centering guide.

*Available bore diameters d: 10, 11, 12, 14, 15, 16, 18, 19, 20, 22, 24, 25, 28, 30, 32, 35, 38, 40, 42, 45, 48, 50, 55 and 60 mm.

**Available bore diameters d₃: 15, 16, 19, 20, 24, 25, 28, 30, 32, 35, 38, 40, 42, 45, 48, 50 and 55 mm.

Example for Ordering

Type	Art.-No.	Preset limit torque	Bore d	Bore d ₃	with proximity switch
STE 30. 1	4479-625 001	10 Nm	12 mm	20 mm	See pages 62 and 63

Torque type

End number

with balls

with torsionally rigid shaft coupling

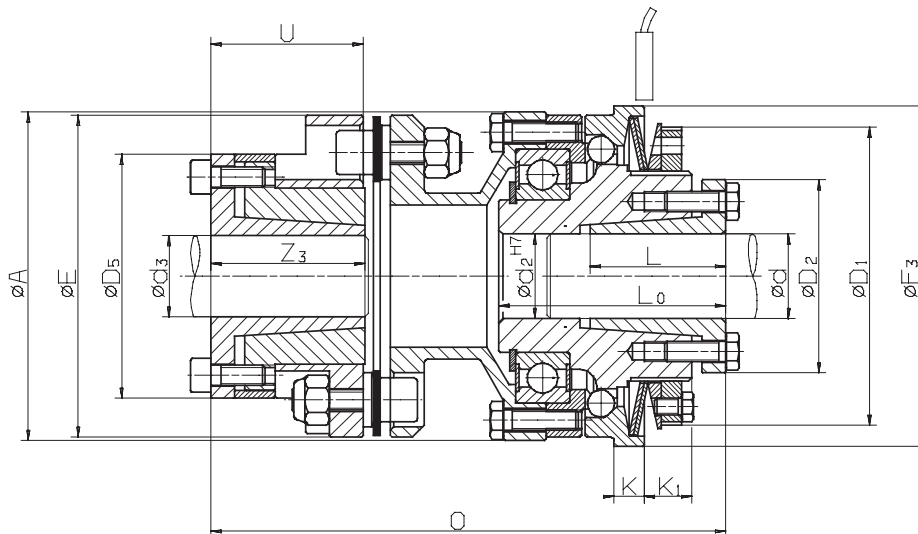

Installation must be shut down as soon as torque limiter responds

25-1

Technical Data

Type	Art.-No.	Torque type 1			Torque type 2			Torque type 3		
		Limit torque Nm	max. speed min ⁻¹	End number	Limit torque Nm	max. speed min ⁻¹	End number	Limit torque Nm	max. speed min ⁻¹	End number
STL 30.x	4479-425xxx	5 - 14	4 000	001	10 - 28	4 000	002	20 - 60	4 000	003
STL 40.x	4479-430xxx	9 - 27	3 000	001	18 - 54	3 000	002	38 - 115	3 000	003
STL 45.x	4479-440xxx	19 - 60	2 500	001	38 - 125	2 500	002	70 - 255	2 500	003
STL 55.x	4479-450xxx	35 - 110	2 000	001	80 - 220	2 000	002	160 - 440	2 000	003
STL 65.x	4479-460xxx	80 - 185	1 200	001	160 - 370	1 200	002	320 - 740	1 200	003

Dimensions

Type	Art.-No.	Bore d*		Bore d ₃ **		A	D ₁	D ₂	D ₅	E	F ₃	K	K ₁	L	L ₀	O	U	Z ₃	Engage-ment travel
		min. mm	max. mm	mm	mm	mm	mm	mm	mm	mm	mm	mm	mm	mm	mm	mm	mm	mm	mm
STL 30.x	4479-425xxx	10	20	11	20	65	63	40,5	42	53	70	7	12	26	47	95,5	25,5	26,5	1,2
STL 30.x	4479-425xxx	19	25	11	20	65	63	42	42	53	70	7	12	26	47	95,5	25,5	26,5	1,2
STL 40.x	4479-430xxx	15	30	15	30	80	77	57	58	72	85	8	12	31	56	114,5	33	31	1,5
STL 45.x	4479-440xxx	19	40	19	30	97	88	64	58	72	100	9	14	40	67	128	33	31	1,8
STL 45.x	4479-440xxx	19	40	24	42	97	88	64	72	89	100	9	14	31	67	150	44,5	45	1,8
STL 55.x	4479-450xxx	32	50	24	42	111	100	73,5	72	89	115	10	16	29	73	153,5	44,5	45	2,0
STL 65.x	4479-460xxx	32	50	32	42	131	122	73,5	79	118	135	12	21	29	85	163,5	35	29	2,2
STL 65.x	4479-460xxx	55	60	45	60	131	122	89	92	118	135	12	21	45,5	86	172,5	44	44	2,2

Hub bore diameter d₂ is equal to the selected diameter d and serves as an additional centering guide.

*Available bore diameters d: 10, 11, 12, 14, 15, 16, 18, 19, 20, 22, 24, 25, 28, 30, 32, 35, 38, 40, 42, 45, 48, 50, 55 and 60 mm.

**Available bore diameters d₃: 15, 16, 19, 20, 24, 25, 28, 30, 32, 35, 38, 40, 42, 45, 48, 50 and 55 mm.

Example for Ordering

Type	Art.-No.	Preset limit torque	Bore d	Bore d ₃	with proximity switch
STL 55. 3	4479-450 003	420 Nm	45 mm	35 mm	See pages 62 and 63

Torque type

End number

with single rollers

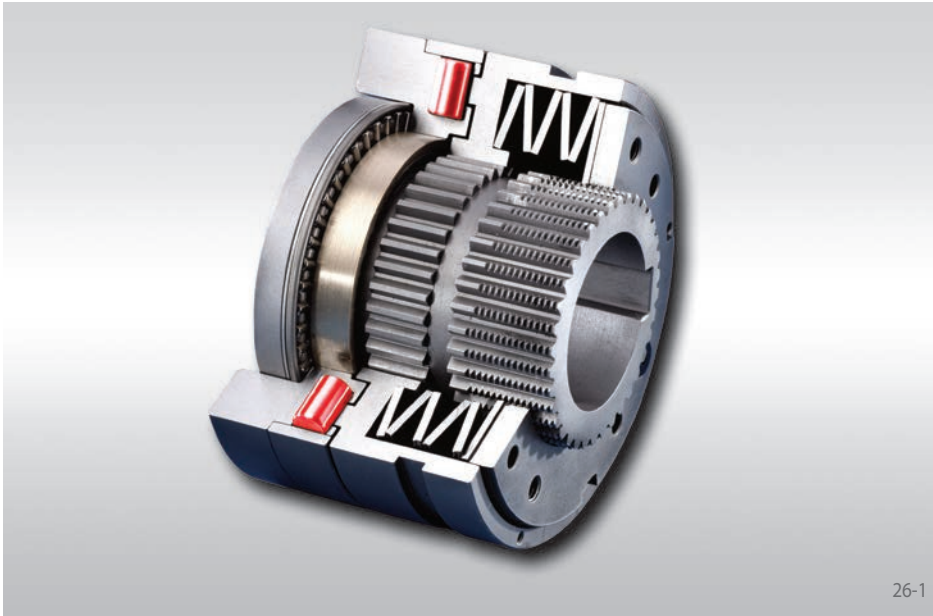

Advantages

- Synchronous re-engagement after 360°
- Integral fixed bearing
- Driving keyway in the connecting flange for maximum load capacity
- Calibrated micro adjustment of torque setting possible, even post-installation
- Cost effective

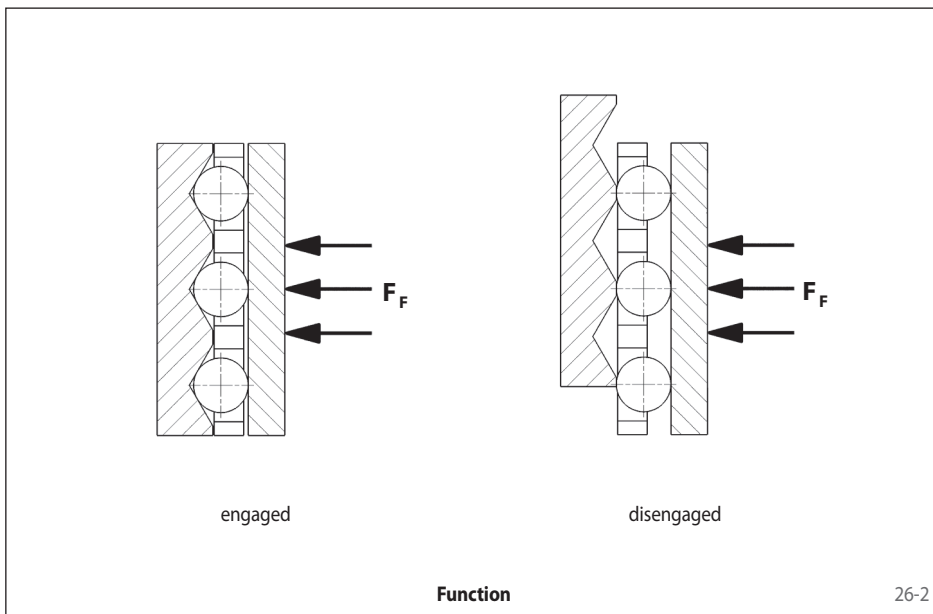

The Single Roller Principle

The torque is transmitted via rollers which are pressed by Belleville springs into detents. When the preset limit torque has been reached, the detent ring is axially displaced. Re-engagement is effected synchronously after 360° due to the asymmetrical division of the detents.

Function

- When the preset limit torque has been reached the SIKUMAT® ratchets.
- Following elimination of overload automatic synchronous re-engagement of the SIKUMAT® to the starting position after 360°.
- The overload can be indicated by a proximity switch. This means that the drive can be switched off immediately or another control function can be activated.

with single rollers

Types

Series SN - Basic version with flange connection

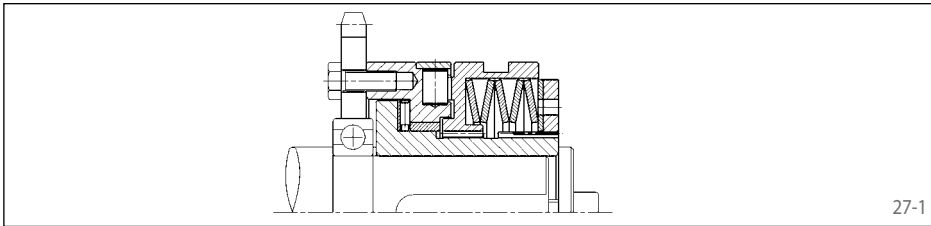

For attaching chain wheels, belt pulleys, gear wheels etc. Bearing of attached component on the shaft to be provided by the customer.

Page 28

Series SNR - with short hub and integral needle bearing

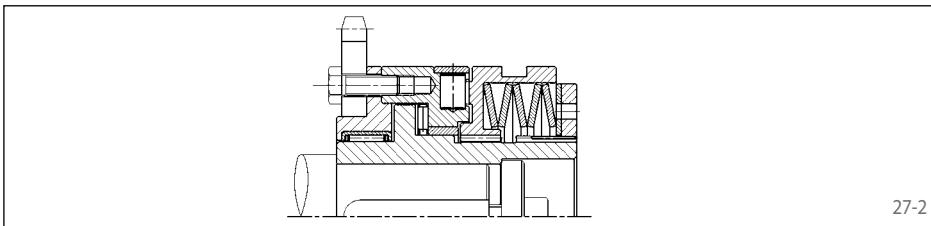

With short hub and needle bearing for narrow components to be connected.

Page 29

Series SNG - with long hub

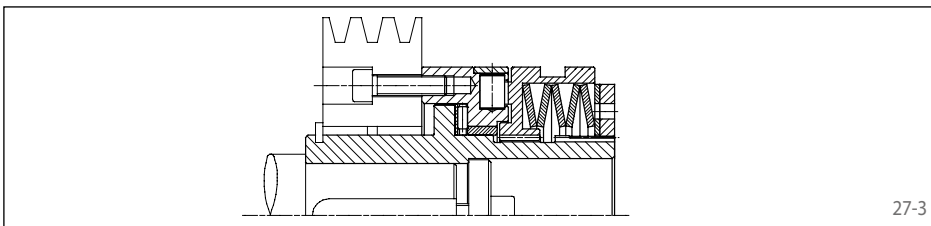

With long hub for wide components to be connected. Bearing of the attached component in the form of plain or needle bearing to be provided by the customer.

Page 30

Series SNE - with flexible shaft coupling

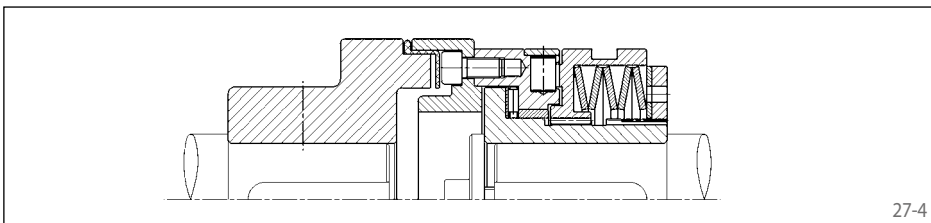

For flexible connection of two shafts. The flexible elements are oil-proof.

Page 31

Notes

Torque setting

The limit torque can be set at the factory on request. Setting or modification of the limit torque can also be carried out by the customer. See operating instructions for further details.

Proximity switch

The overload can be indicated by a non-contact or a mechanical proximity switch. Further details on pages 62 and 63.

with single rollers

Basic version with flange connection

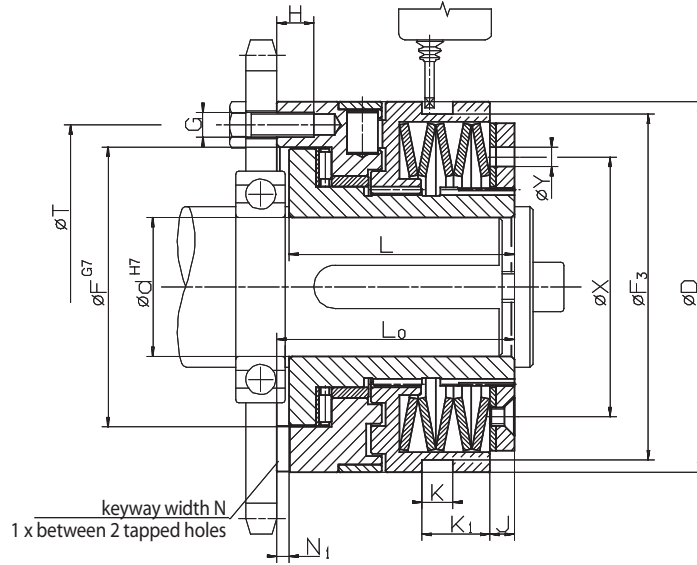

Z = number of tapped holes G on pitch circle T · Installation must be shut down as soon as torque limiter responds

28-1

Technical Data

Type	Art.-No.	Torque type 1			Torque type 2			Torque type 3		
		Limit torque Nm	max. speed min^{-1}	End number	Limit torque Nm	max. speed min^{-1}	End number	Limit torque Nm	max. speed min^{-1}	End number
SN 32.x	4470-020xxx	5 - 10	1000	801	10 - 20	1000	802	20 - 40	500	803
SN 40.x	4470-025xxx	12 - 25	950	801	25 - 50	950	802	50 - 100	450	803
SN 55.x	4470-035xxx	25 - 50	800	801	50 - 100	800	802	100 - 200	400	803
SN 65.x	4470-045xxx	50 - 100	650	801	100 - 200	650	802	200 - 450	300	803
SN 80.x	4470-055xxx	100 - 200	550	801	200 - 400	550	802	400 - 800	250	803
SN 90.x	4470-065xxx	170 - 450	400	801	350 - 900	400	802	600 - 1800	150	803

Dimensions

Type	Art.-No.	Bore d		D	F	F ₃	G	H	J	K	K ₁	L	L ₀	N	N ₁	T	X	Y	Z	Engage-ment travel mm
		min. mm	max. mm																	
SN 32.x	4470-020xxx	7	20	55	41	50	M 5	6,5	3	9	13,5	35	38,5	6	3,1	48	38,5	5	6	1,2
SN 40.x	4470-025xxx	10	25	82	60	72,5	M 5	8	6	9	14,5	48	52	6	3,1	70	54	6	6	1,8
SN 55.x	4470-035xxx	14	35	100	78	90,5	M 6	10	6	9	15	56	61	8	3,6	89	70	6	6	2,0
SN 65.x	4470-045xxx	18	45	120	90,5	112	M 8	12	8,5	10	22,5	72	78	10	4,1	105	84	6	6	2,2
SN 80.x	4470-055xxx	24	55	146	105	140	M 10	15	11	9	25	93,5	100	12	4,1	125	108	7	6	2,5
SN 90.x	4470-065xxx	30	70 ¹⁾	176	120,5	170	M 12	17	12	9	30	107	113,5	14	4,6	155	129	10	6	3,0

Keyway as per DIN 6885, page 1 · Tolerance of keyway width JS9

¹⁾ Keyway as per DIN 6885, page 3 · Tolerance of keyway width JS9

Example for Ordering

Type	Art.-No.	Preset limit torque	Bore d	with proximity switch
SN 32. 3	4470-020 803	30 Nm	9 mm	See pages 62 and 63

Torque type

End number

with single rollers
with short hub and integral needle bearing

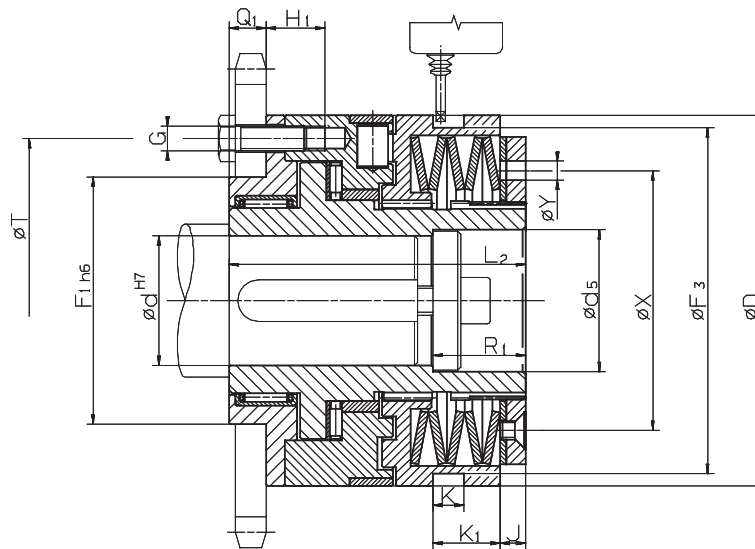

Z = number of tapped holes G on pitch circle T · Installation must be shut down as soon as torque limiter responds

29-1

Technical Data

Type	Art.-No.	Torque type 1			Torque type 2			Torque type 3		
		Limit torque Nm	max. speed min ⁻¹	End number	Limit torque Nm	max. speed min ⁻¹	End number	Limit torque Nm	max. speed min ⁻¹	End number
SNR 32.x	4470-920xxx	5 - 10	1000	801	10 - 20	1000	802	20 - 40	500	803
SNR 40.x	4470-925xxx	12 - 25	950	801	25 - 50	950	802	50 - 100	450	803
SNR 55.x	4470-935xxx	25 - 50	800	801	50 - 100	800	802	100 - 200	400	803
SNR 65.x	4470-945xxx	50 - 100	650	801	100 - 200	650	802	200 - 450	300	803
SNR 80.x	4470-955xxx	100 - 200	550	801	200 - 400	550	802	400 - 800	250	803
SNR 90.x	4470-965xxx	170 - 450	400	801	350 - 900	400	802	600 - 1800	150	803

Dimensions

Type	Art.-No.	Bore d		d ₅	D	F ₁	F ₃	G	H ₁	J	K	K ₁	L ₂	Q ₁	R ₁	T	X	Y	Z	Engage-ment travel mm
		min. mm	max. mm																	
SNR 32.x	4470-920xxx	7	20	21	55	38	50	M5	11,5	3	9	13,5	51,5	8	15	48	38,5	5	6	1,2
SNR 40.x	4470-925xxx	10	25	26	82	50	72,5	M5	16	6	9	14,5	70	10	20	70	54	6	6	1,8
SNR 55.x	4470-935xxx	14	35	36	100	60	90,5	M6	15	6	9	15	78	12	25	89	70	6	6	2,0
SNR 65.x	4470-945xxx	18	45	46	120	80	112	M8	18	8,5	10	22,5	96	12	30	105	84	6	6	2,2
SNR 80.x	4470-955xxx	24	55	56	146	100	140	M10	23,5	11	9	25	124,5	16	30	125	108	7	6	2,5
SNR 90.x	4470-965xxx	30	70 ¹⁾	66	176	120	170	M12	25,5	12	9	30	140	18	30	155	129	10	6	3,0

Keyway as per DIN 6885, page 1 · Tolerance of keyway width JS9

¹⁾ Keyway as per DIN 6885, page 3 · Tolerance of keyway width JS9

Example for Ordering

Type	Art.-No.	Preset limit torque	Bore d	with proximity switch
SNR 32. 2	4470-920 802	15 Nm	13 mm	See pages 62 and 63

Torque type

End number

with single rollers
with long hub

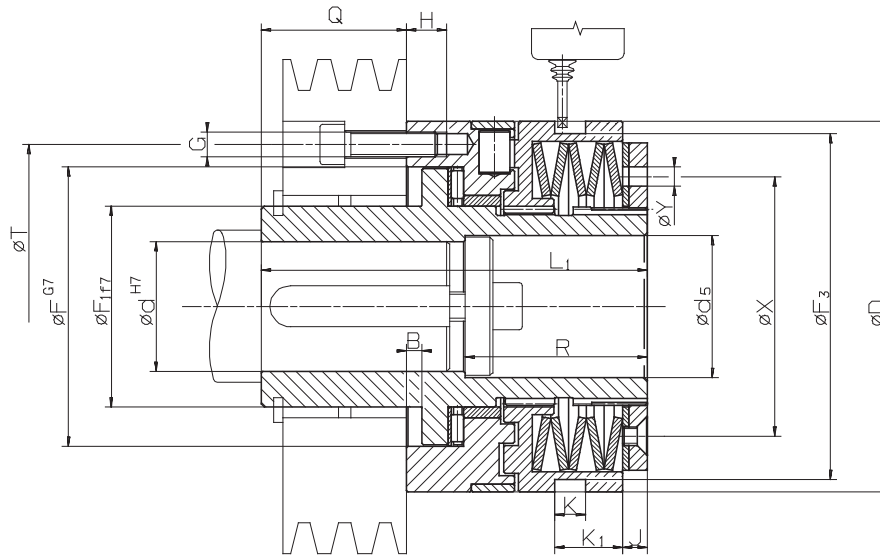

Z = number of tapped holes G on pitch circle T · Installation must be shut down as soon as torque limiter responds

30-1

Technical Data

Type	Art.-No.	Torque type 1			Torque type 2			Torque type 3		
		Limit torque Nm	max. speed min ⁻¹	End number	Limit torque Nm	max. speed min ⁻¹	End number	Limit torque Nm	max. speed min ⁻¹	End number
SNG 32.x	4470-120xxx	5 - 10	1000	801	10 - 20	1000	802	20 - 40	500	803
SNG 40.x	4470-125xxx	12 - 25	950	801	25 - 50	950	802	50 - 100	450	803
SNG 55.x	4470-135xxx	25 - 50	800	801	50 - 100	800	802	100 - 200	400	803
SNG 65.x	4470-145xxx	50 - 100	650	801	100 - 200	650	802	200 - 450	300	803
SNG 80.x	4470-155xxx	100 - 200	550	801	200 - 400	550	802	400 - 800	250	803
SNG 90.x	4470-165xxx	170 - 450	400	801	350 - 900	400	802	600 - 1800	150	803

Dimensions

Type	Art.-No.	Bore d		d ₅	B	D	F	F ₁	F ₃	G	H	J	K	K ₁	L ₁	Q	R	T	X	Y	Z	Engage-ment travel mm
		min. mm	max. mm																			
SNG 32.x	4470-120xxx	7	20	21	4	55	41	28	50	M 5	6,5	3	9	13,5	66	27,5	25,5	48	38,5	5	6	1,2
SNG 40.x	4470-125xxx	10	25	26	4	82	60	38	72,5	M 5	8	6	9	14,5	83	33	35	70	54	6	6	1,8
SNG 55.x	4470-135xxx	14	35	36	5	100	78	52	90,5	M 6	10	6	9	15	100	39	45	89	70	6	6	2,0
SNG 65.x	4470-145xxx	18	45	46	5	120	90,5	65	112	M 8	12	8,5	10	22,5	125	47	59	105	84	6	6	2,2
SNG 80.x	4470-155xxx	24	55	56	6,5	146	105	78	140	M 10	15	11	9	25	152,5	52,5	60	125	108	7	6	2,5
SNG 90.x	4470-165xxx	30	70 ¹⁾	66	6,5	176	120,5	90	170	M 12	17	12	9	30	171	57,5	60	155	129	10	6	3,0

Keyway as per DIN 6885, page 1 · Tolerance of keyway width JS9
¹⁾ Keyway as per DIN 6885, page 3 · Tolerance of keyway width JS9

Example for Ordering

Type	Art.-No.	Preset limit torque	Bore d	with proximity switch
SNG 32. 2	4470-120 802	15 Nm	10 mm	See pages 62 and 63

Torque type

End number

with single rollers
with flexible shaft coupling

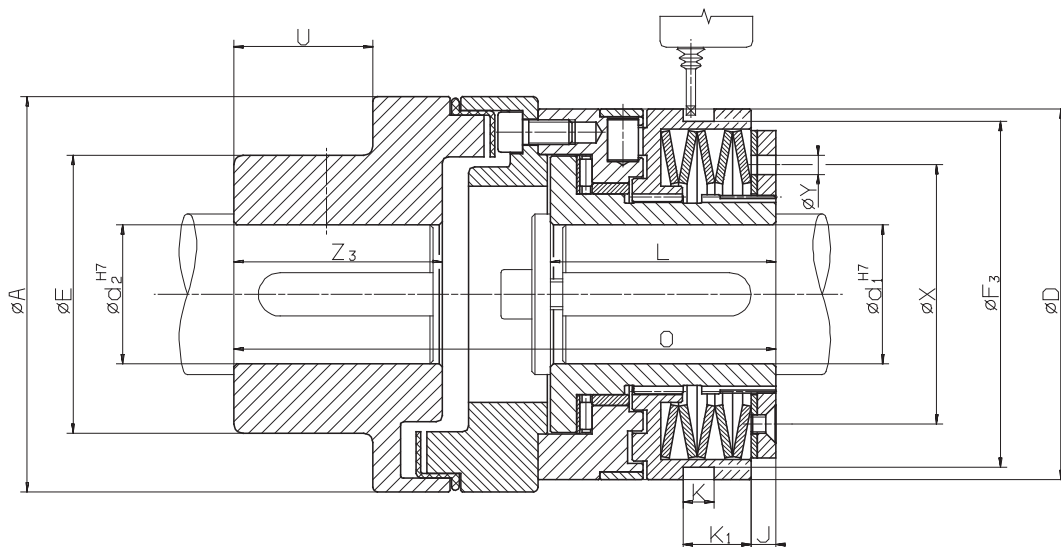

Installation must be shut down as soon as torque limiter responds

31-1

Technical Data

Type	Art.-No.	Torque type 1			Torque type 2			Torque type 3		
		Limit torque Nm	max. speed min ⁻¹	End number	Limit torque Nm	max. speed min ⁻¹	End number	Limit torque Nm	max. speed min ⁻¹	End number
SNE 32.x	4470-620xxx	5 - 10	1000	801	10 - 20	1000	802	20 - 40	500	803
SNE 40.x	4470-625xxx	12 - 25	950	801	25 - 50	950	802	50 - 100	450	803
SNE 55.x	4470-635xxx	25 - 50	800	801	50 - 100	800	802	100 - 200	400	803
SNE 65.x	4470-645xxx	50 - 100	650	801	100 - 200	650	802	200 - 450	300	803
SNE 80.x	4470-655xxx	100 - 200	550	801	200 - 400	550	802	400 - 800	250	803
SNE 90.x	4470-665xxx	170 - 450	400	801	350 - 900	400	802	600 - 1800	150	803

Dimensions

Type	Art.-No.	Bore d ₁		d ₂	A	E	D	F ₃	J	K	K ₁	L	O	U	X	Y	Z ₃	Engage-ment travel
		min. mm	max. mm															
SNE 32.x	4470-620xxx	7	20	30	67	46	55	50	3	9	13,5	35	86	15	38,5	5	28	1,2
SNE 40.x	4470-625xxx	10	25	50	112	79	82	72,5	6	9	14,5	48	137,5	38	54	6	58	1,8
SNE 55.x	4470-635xxx	14	35	50	112	79	100	90,5	6	9	15	56	147	38	70	6	58	2,0
SNE 65.x	4470-645xxx	18	45	60	128	90	120	112	8,5	10	22,5	72	176,5	45	84	6	67	2,2
SNE 80.x	4470-655xxx	24	55	60	148	90	146	140	11	9	25	93,5	211,5	45	108	7	67	2,5
SNE 90.x	4470-665xxx	30	70 ¹⁾	70	177	107	176	170	12	9	30	107	242,5	52	129	10	75	3,0
SNE 90.x	4470-665xxx	30	70 ¹⁾	90	198	140	176	170	12	9	30	107	272	52	129	10	75	3,0

Keyway as per DIN 6885, page 1 · Tolerance of keyway width JS9

¹⁾ Keyway as per DIN 6885, page 3 · Tolerance of keyway width JS9

Example for Ordering

Type	Art.-No.	Preset limit torque	Bore d ₁	Bore d ₂	with proximity switch
SNE 32. 2	4470-620 802	15 Nm	10 mm	20 mm	See pages 62 and 63

└─┬─┘
Torque type

└─┬─┘
End number

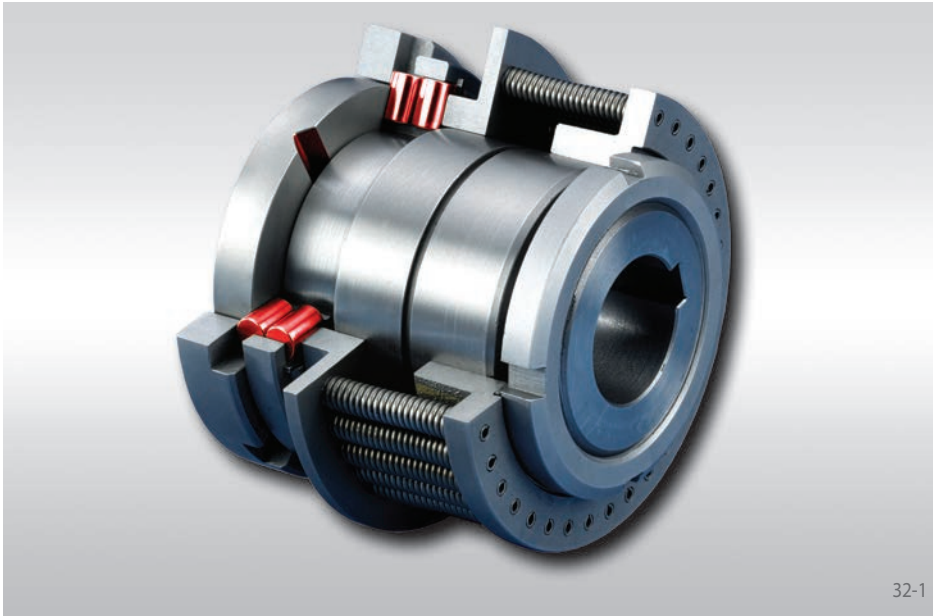

32-1

Advantages

- High degree of consistency of limit torque over the duration of operation through double roller principle
- Synchronous re-engagement after 360°
- Torques up to 10 000 Nm
- For shaft diameters up to 125 mm

The Double Roller Principle

The torque is transmitted via six pairs of rollers which are pressed by coil springs into detents. When the preset limit torque has been reached, the rollers move against the spring force up the sloping surface and disengage. This characteristic combined with the particular geometry of the detents provide a high degree of consistency to the limit torque of the SIKUMAT® over the duration of the operating period. Re-engagement is effected synchronously after 360° due to the asymmetrical division of the detents.

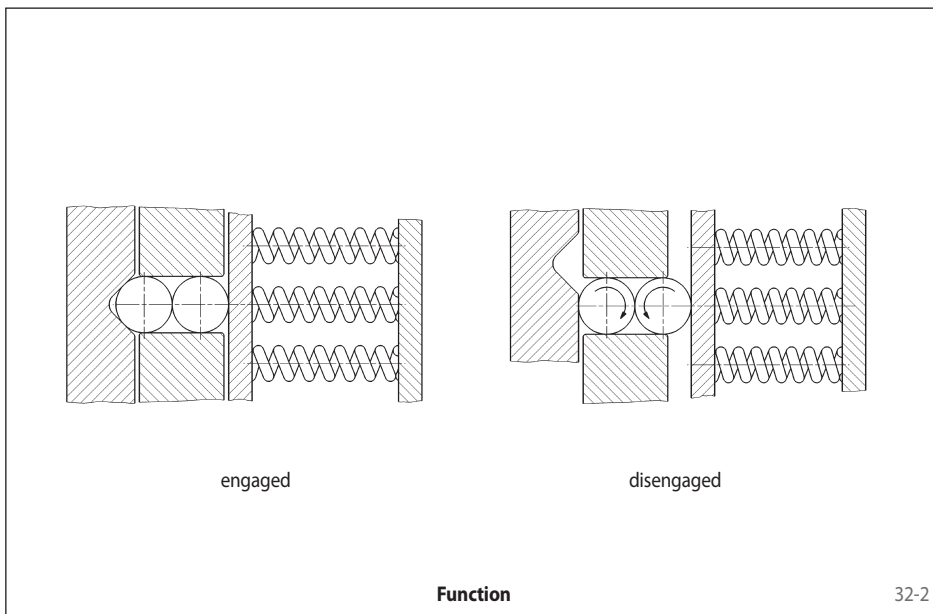

32-2

Function

- When the preset limit torque has been reached the SIKUMAT® ratchets.
- Following elimination of overload automatic synchronous re-engagement of the SIKUMAT® to the starting position after 360°.
- The overload can be indicated by a proximity switch. This means that the drive can be switched off immediately or another control function can be activated.

with double rollers

Types

Series SA - Basic version with flange connection

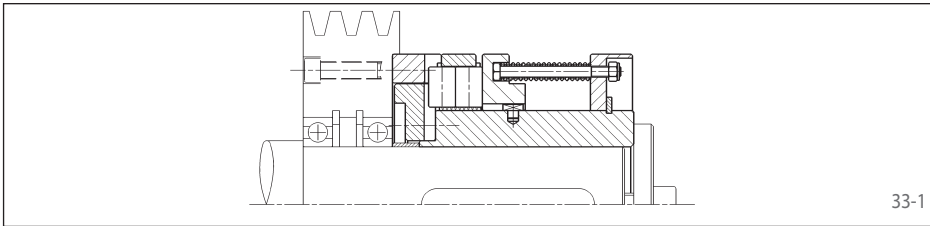

For attaching chain wheels, belt pulleys, gear wheels etc. Bearing of attached component on the shaft to be provided by the customer.

Page 34

Series SAG - with long hub

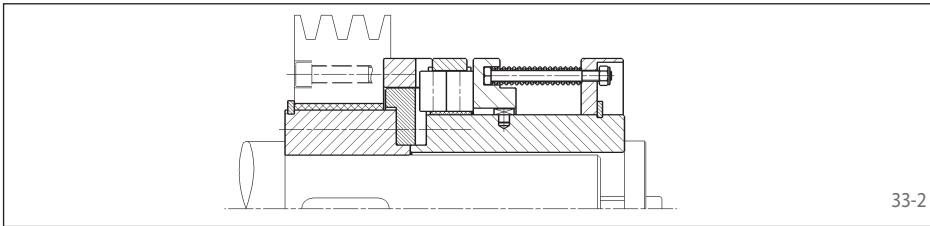

With long hub for wide components. Plain bearings are included in delivery.

Page 35

Series SAE - with flexible shaft coupling

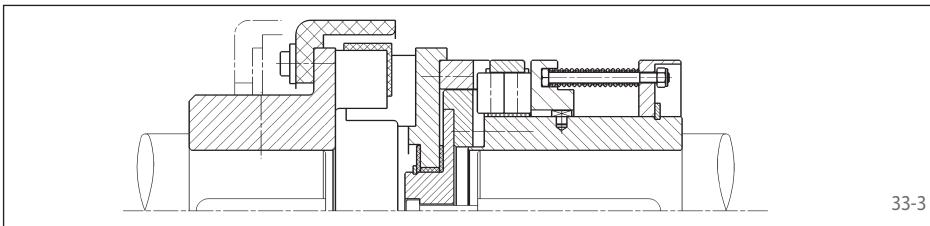

For flexible connection of two shafts. The flexible elements are oil-proof.

Page 36

Series SAL - with torsionally rigid shaft coupling

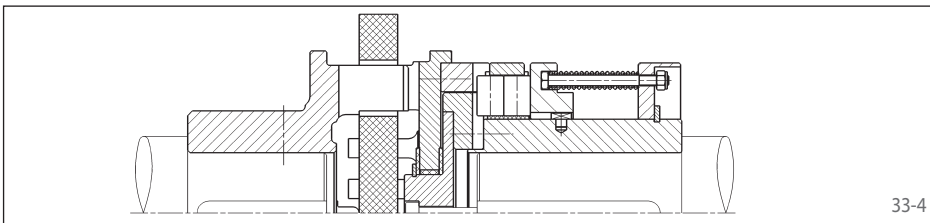

For torsionally rigid connection of two shafts. Possibility to compensate for large radial and angular displacements.

Page 37

Notes

Torque setting

The limit torque is normally set at the factory. Setting or modification of the limit torque can also be carried out by the customer but no unauthorised adjustment should be carried out by the machine operator. See operating instructions for further details.

Proximity switch

The overload can be indicated by a non-contact or a mechanical proximity switch. Further details on pages 62 and 63.

with double rollers

Basic version with flange connection

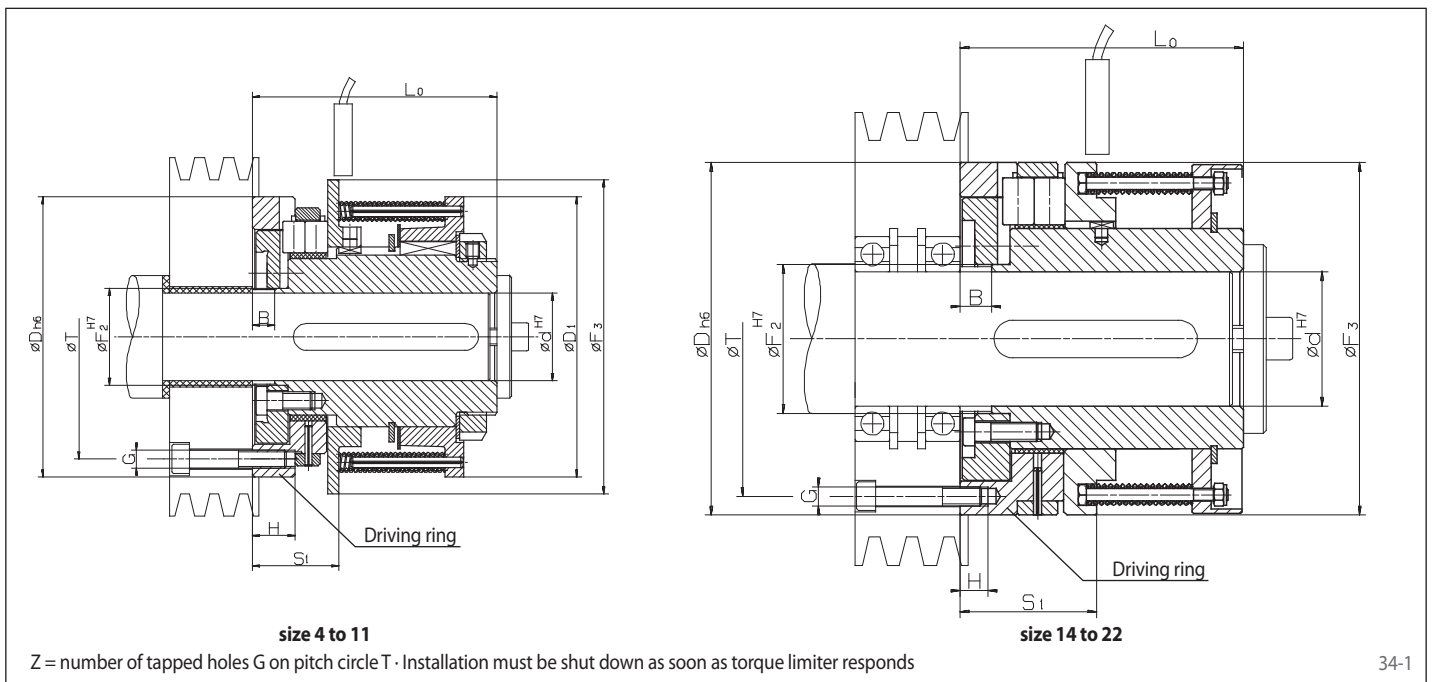

34-1

Technical Data

Type	Art.-No.	Limit torque	max. speed
		Nm	min ⁻¹
SA 4	4470-004800	7 - 80	1500
SA 7	4470-007800	26 - 310	800
SA 11	4470-011800	105 - 1250	500
SA 14	4470-014800	210 - 2500	400
SA 18	4470-018800	420 - 5000	315
SA 22	4470-022800	840 - 10000	250

Dimensions

Type	Art.-No.	Bore d		B	D	D ₁	F ₂	F ₃	G	H	L ₀	S ₁	T	Z	Engage-ment travel
		min. mm	max. mm												
SA 4	4470-004800	9	25	8	80	80	27	90	M 6	11	71	24	71	3	1,6
SA 7	4470-007800	25	40	10	125	125	43	140	M 8	19	109	38	109	6	2,5
SA 11	4470-011800	30	65	15	180	200	75	212	M 10	16	175	61	160	6	4,0
SA 14	4470-014800	50	80	20	224	-	95	224	M 12	18	180	87	200	6	5,0
SA 18	4470-018800	65	100	24	280	-	118	280	M 16	25	224	110	250	6	6,2
SA 22	4470-022800	80	125	30	355	-	150	355	M 20	30	280	140	315	6	8,0

Keyway as per DIN 6885, page 1 · Tolerance of keyway width P9

Example for Ordering

Type	Art.-No.	Preset limit torque	Bore d	with proximity switch
SA 4	4470-004 800	9 Nm	12 mm	See pages 62 and 63

with double rollers
with long hub

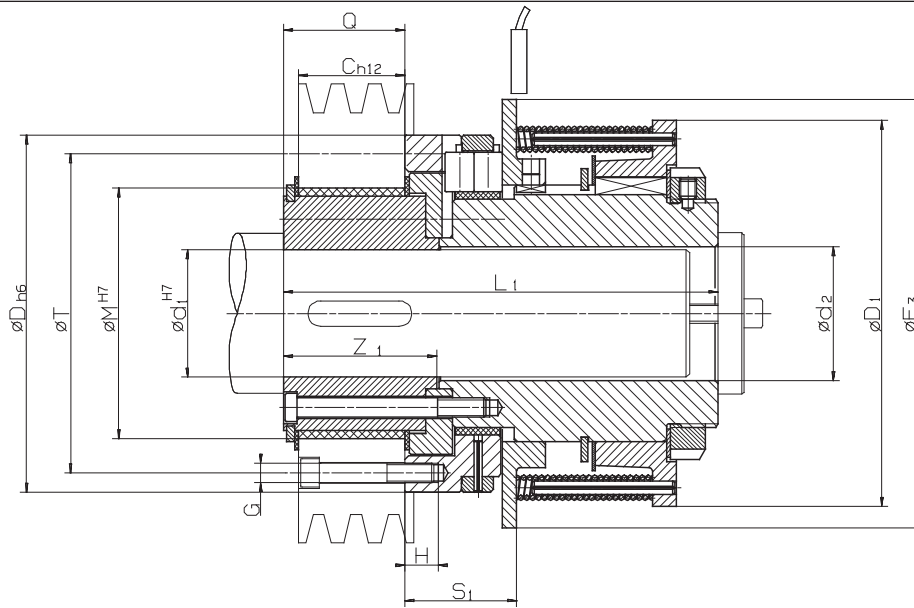

illustrated: size 4 to 11

Z = number of tapped holes G on pitch circle T · Installation must be shut down as soon as torque limiter responds

35-1

Technical Data

Type	Art.-No.	Limit torque	max. speed
		Nm	min ⁻¹
SAG 4	4470-104800	7 - 80	1500
SAG 7	4470-107800	26 - 310	800
SAG 11	4470-111800	105 - 1250	500
SAG 14	4470-114800	210 - 2500	400

Dimensions

Type	Art.-No.	Bore d ₁		C	D	D ₁	F ₃	G	H	L ₁	M	Q	S ₁	T	Z	Z ₁	Engage-ment travel
		min. mm	max. mm														
SAG 4	4470-104800	9	25	25	80	80	90	M 6	11	103	55	32	24	71	3	39	1,6
SAG 7	4470-107800	25	40	40	125	125	140	M 8	19	155	80	46	38	109	6	55	2,5
SAG 11	4470-111800	40	65	63	180	200	212	M 10	16	250	120	75	61	160	6	87	4,0
SAG 14	4470-114800	50	80	80	224	224	224	M 12	18	275	155	95	87	200	6	109	5,0

Bore d₂ is 0,2...0,5 mm larger than d₁ for sizes 4 - 7

Bore d₂ is 0,5...1,0 mm larger than d₁ for sizes 11 - 14

Keyway as per DIN 6885, page 1 · Tolerance of keyway width P9

Example for Ordering

Type	Art.-No.	Preset limit torque	Bore d ₁	with proximity switch
SAG 4	4470-104 800	27 Nm	16 mm	See pages 62 and 63

with double rollers
with flexible shaft coupling

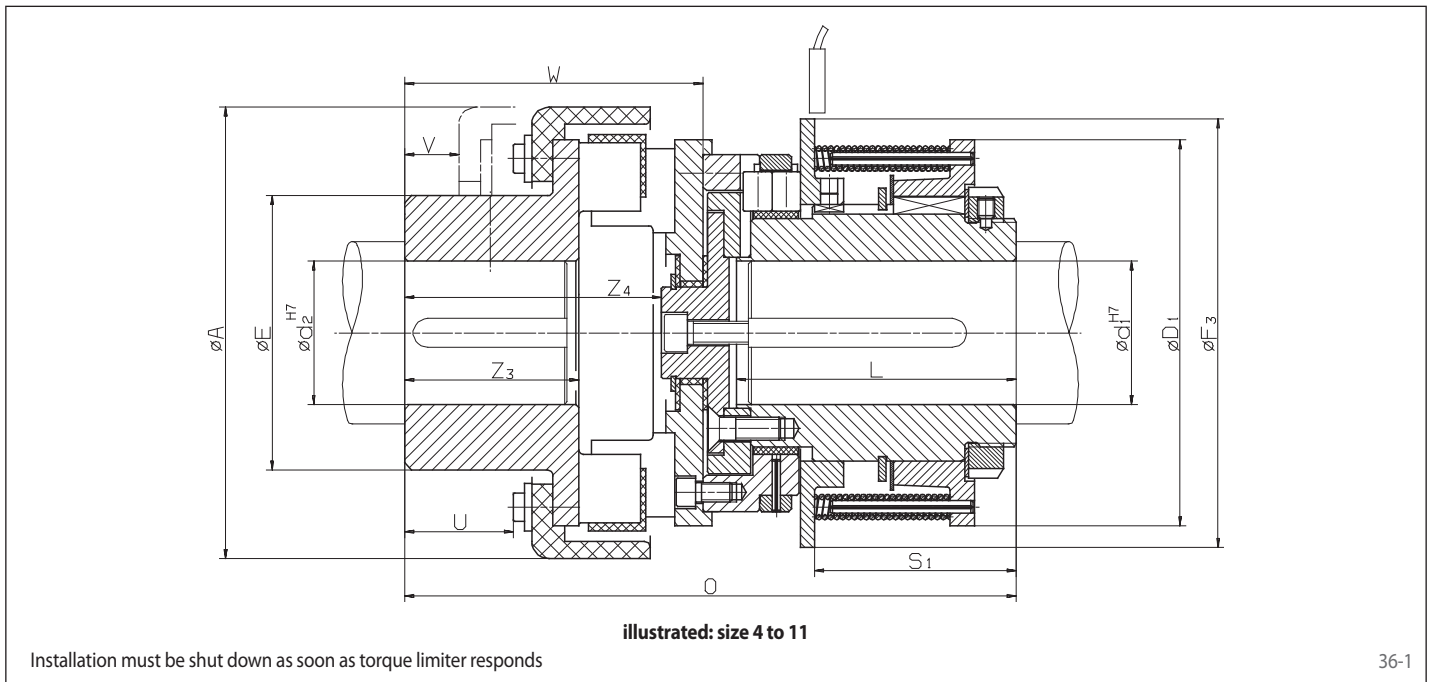

Technical Data

Type	Art.-No.	Limit torque	max. speed
		Nm	min ⁻¹
SAE 4	4470-604800	7 - 80	1500
SAE 7	4470-607800	26 - 310	800
SAE 11	4470-611800	105 - 1250	500
SAE 14	4470-614800	210 - 2500	400
SAE 18	4470-618800	420 - 5000	315
SAE 22	4470-622800	840 - 10000	250

Dimensions

Type	Art.-No.	Bore d ₁		Bore d ₂		A	D ₁	F ₃	E	L	O	S ₁	U	V	W	Z ₃	Z ₄	Engage-ment travel
		min. mm	max. mm	min. mm	max. mm													
SAE 4	4470-604800	9	25	5	45	114	80	90	72	63	146	47	28	19	75	41	63	1,6
SAE 7	4470-607800	25	40	20	60	158	125	140	96	99	221	71	39	21	112	61	97	2,5
SAE 11	4470-611800	30	65	25	80	230	180	212	130	160	318	114	49	21	143	82	124	4,0
SAE 14	4470-614800	50	80	45	100	294	224	224	160	160	359	93	56	17	179	97	153	5,0
SAE 18	4470-618800	65	100	60	120	330	280	280	195	200	430	114	80	25	206	116	179	6,2
SAE 22	4470-622800	80	125	75	160	432	355	355	255	250	563	140	104	31	283	160	247	8,0

Keyway as per DIN 6885, page 1 · Tolerance of keyway width P9

Example for Ordering

Type	Art.-No.	Preset limit torque	Bore d ₁	Bore d ₂	with proximity switch
SAE 4	4470-604 800	40 Nm	29 mm	40 mm	See pages 62 and 63

with double rollers
with torsionally rigid shaft coupling

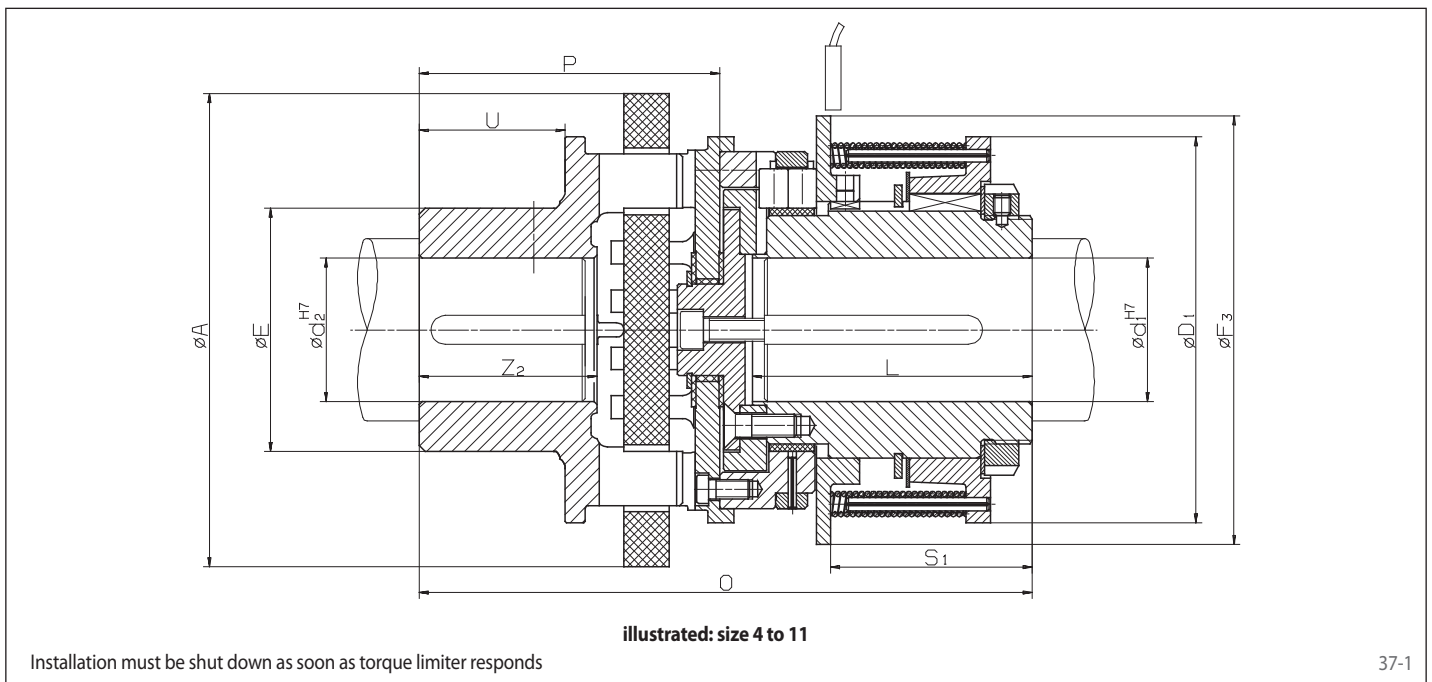

37-1

Technical Data

Type	Art.-No.	Limit torque	max. speed
		Nm	min ⁻¹
SAL 4	4470-404800	7 - 80	1500
SAL 7	4470-407800	26 - 310	800
SAL 11	4470-411800	105 - 1250	500
SAL 14	4470-414800	210 - 2500	400
SAL 18	4470-418800	420 - 5000	315
SAL 22	4470-422800	840 - 10000	250

Dimensions

Type	Art.-No.	Bore d_1		Bore d_2		A	D_1	E	F_3	L	O	P	U	S_1	Z_2	Engage-ment travel
		min. mm	max. mm	min. mm	max. mm											
SAL 4	4470-404800	9	25	16	35	110	80	53	90	63	148	77	33	47	42	1,6
SAL 7	4470-407800	25	40	30	50	160	125	85	140	99	214	105	51	71	62	2,5
SAL 11	4470-411800	30	65	50	90	250	200	150	212	160	335	160	81	114	100	4,0
SAL 14	4470-414800	50	80	60	110	315	224	175	224	160	384	204	101	93	124	5,0
SAL 18	4470-418800	65	100	60	110	315	280	175	280	200	462	238	101	114	124	6,2
SAL 22	4470-422800	80	125	75	140	400	355	216	355	250	600	320	130	140	160	8,0

Permissible radial displacement $0,015 \times \varnothing A$ · Permissible angular displacement max. 3°
Keyway as per DIN 6885, page 1 · Tolerance of keyway width P9

Example for Ordering

Type	Art.-No.	Preset limit torque	Bore d_1	Bore d_2	with proximity switch
SAL 4	4470-404 800	13 Nm	13 mm	17 mm	See pages 62 and 63

Synchronous Ratcheting SIKUMAT® SU ... – Backlash free RINGSPANN®

with balls

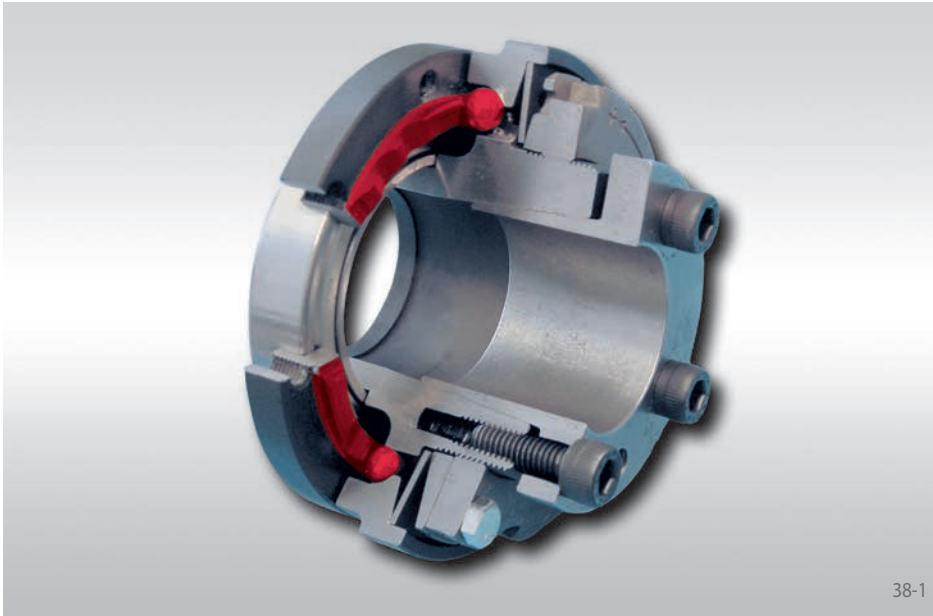

Advantages

- Backlash free in both directions of rotation
- Compact design
- Integral ball bearing for supporting the component to be connected
- Very high response accuracy through the ball principle
- Simple and backlash free fastening onto shaft with integral cone clamping element
- Calibrated micro adjustment of torque setting possible, even post-installation

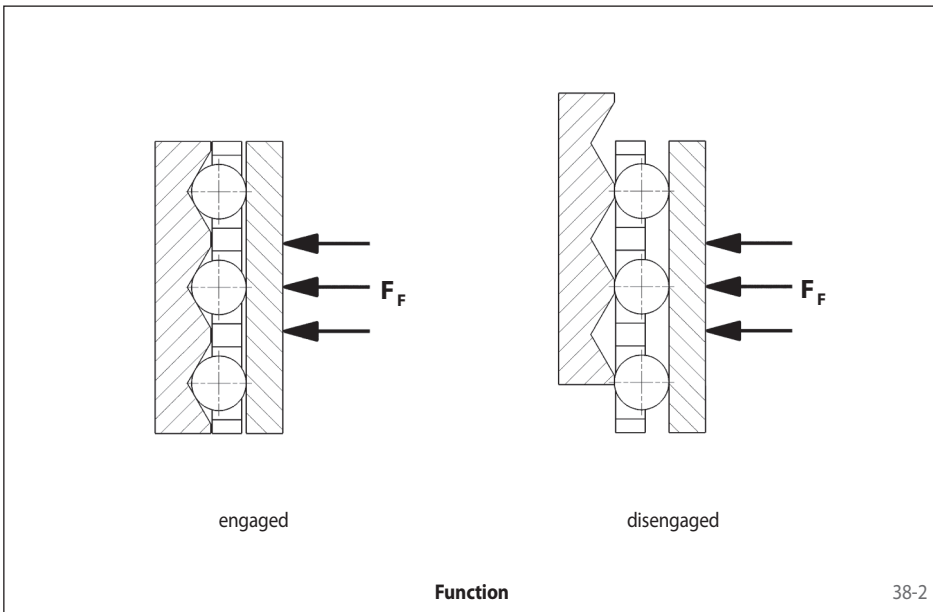

The Ball Principle

The torque is transmitted via balls which are pressed by Belleville springs into v-shaped grooves. The grooves are arranged axially on the output side and radially on the input side, which means that torque can be transmitted backlash free in both directions of rotation. When the preset limit torque has been reached, the groove-ring is displaced. Due to the unsymmetrical division of the grooves, re-engagement is effected synchronously after 360°, as soon as the overload has been eliminated. The negative characteristic disc springs give extremely fast, accurate and consistent overload protection.

Function

- When the preset limit torque has been reached the SIKUMAT® ratchets through.
- Following elimination of overload automatic synchronous re-engagement of the SIKUMAT® to the starting position after 360°.
- The overload can be indicated by a proximity switch. This means that the drive can be switched off immediately or another control function can be activated.

Synchronous Ratcheting SIKUMAT® SU ... – Backlash free RINGSPANN®

with balls

Types

Series SU - Basic version with flange connection

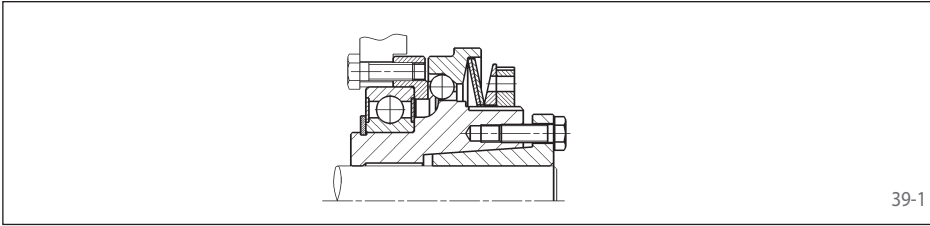

For attaching chain wheels, belt pulleys, gear wheels etc. Support of the component to be connected directly on the integral ball bearing.

Page 40

Series SUG - with long hub

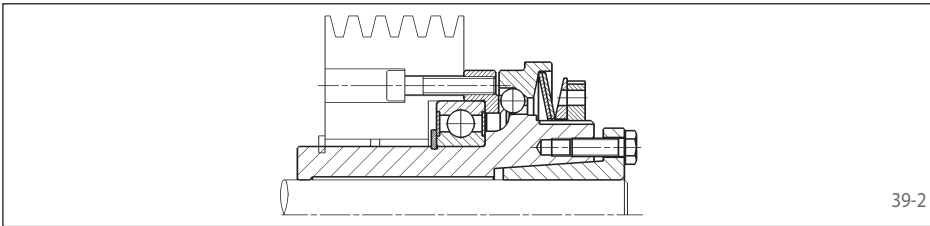

With long hub for wide components to be connected. Support of the component to be connected directly on the integral ball bearing; additional radial bearing to be provided by the customer.

Page 41

Series SUE - with flexible shaft coupling

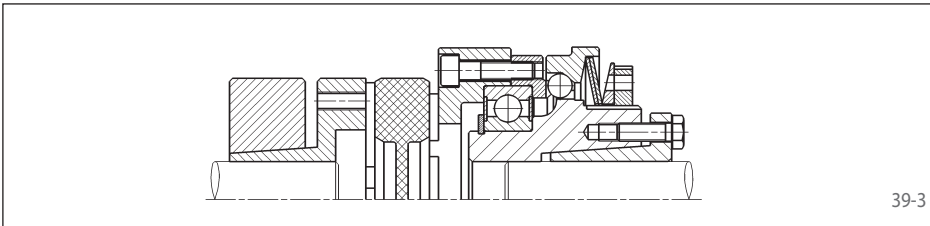

For flexible connection of two shafts.

Page 42

Series SUL - with torsionally rigid shaft coupling

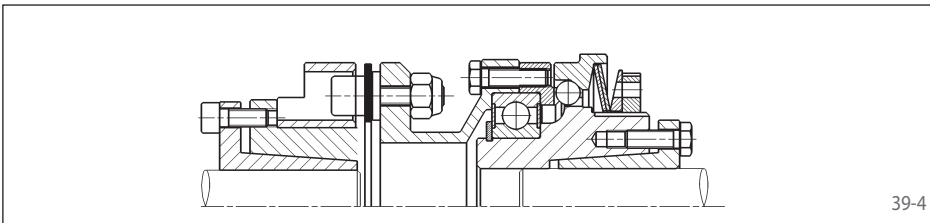

For rigid connection of two shafts.

Page 43

Notes

Torque setting

The limit torque can be set at the factory on request. Setting or modification of the limit torque can also be carried out by the customer. See operating instructions for further details.

Proximity switch

The overload can be indicated by a non-contact or a mechanical proximity switch. Further details on pages 62 and 63.

with balls

Basic version with flange connection

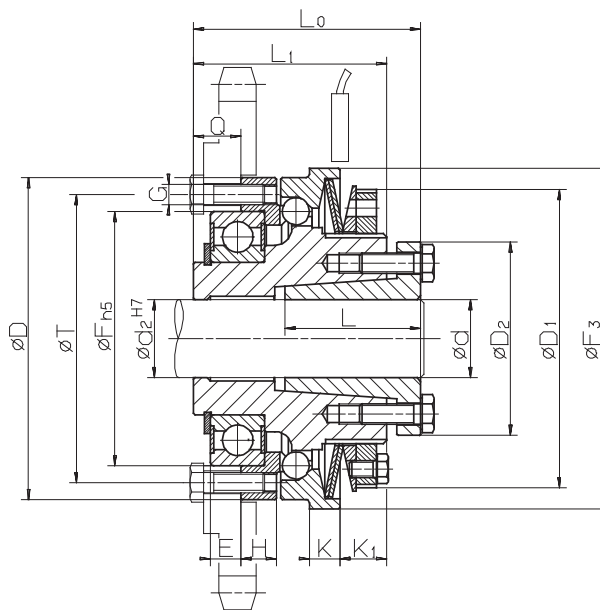

Z = number of tapped holes G on pitch circle T · Installation must be shut down as soon as torque limiter responds

40-1

Technical Data

Type	Art.-No.	Torque type 1			Torque type 2			Torque type 3		
		Limit torque Nm	max. speed min ⁻¹	End number	Limit torque Nm	max. speed min ⁻¹	End number	Limit torque Nm	max. speed min ⁻¹	End number
SU 30.x	4479-025xxx	5 - 14	4000	101	10 - 28	4000	102	20 - 60	4000	103
SU 40.x	4479-030xxx	9 - 27	3000	101	18 - 54	3000	102	38 - 115	3000	103
SU 45.x	4479-040xxx	19 - 60	2500	101	38 - 125	2500	102	70 - 255	2500	103
SU 55.x	4479-050xxx	35 - 110	2000	101	80 - 220	2000	102	160 - 440	2000	103
SU 65.x	4479-060xxx	80 - 185	1200	101	160 - 370	1200	102	320 - 740	1200	103

Dimensions

Type	Art.-No.	Bore d*		D	D ₁	D ₂	E	F	F ₃	G	H	K	K ₁	L	L ₀	L ₁	Q	T	Z	Engage-ment travel mm
		min. mm	max. mm																	
SU 30.x	4479-025xxx	10	20	65	63	40,5	5	47	70	M 4	7,5	7	12	26	47	40	8	56	8	1,2
SU 30.x	4479-025xxx	19	25	65	63	42	5	47	70	M 4	7,5	7	12	26	47	40	8	56	8	1,2
SU 40.x	4479-030xxx	15	30	80	77	57	7	62	85	M 5	8	8	12	31	56	46	11	71	8	1,5
SU 45.x	4479-040xxx	19	30	95	88	57	9	75	100	M 6	10,5	9	14	40	67	57	14	85	8	1,8
SU 45.x	4479-040xxx	32	40	95	88	64	9	75	100	M 6	10,5	9	14	31	67	57	14	85	8	1,8
SU 55.x	4479-050xxx	32	50	110	100	73,5	10	90	115	M 6	12	10	16	29	73	63	16	100	8	2,0
SU 65.x	4479-060xxx	32	50	130	122	73,5	10	100	135	M 8	12	12	21	29	85	75	18	116	8	2,2
SU 65.x	4479-060xxx	55	60	130	122	89	10	100	135	M 8	12	12	21	45,5	86	75	18	116	8	2,2

Hub bore diameter d₂ is equal to the selected diameter d and serves as an additional centering guide.

*Available bore diameters d: 10, 11, 12, 14, 15, 16, 18, 19, 20, 22, 24, 25, 28, 30, 32, 35, 38, 40, 42, 45, 48, 50, 55 and 60 mm.

Example for Ordering

Type	Art.-No.	Preset limit torque	Bore d	with proximity switch
SU 40. 2	4479-030 102	25 Nm	20 mm	See pages 62 and 63

└─┬─┘
Torque type

└─┬─┘
End number

with balls
with long hub

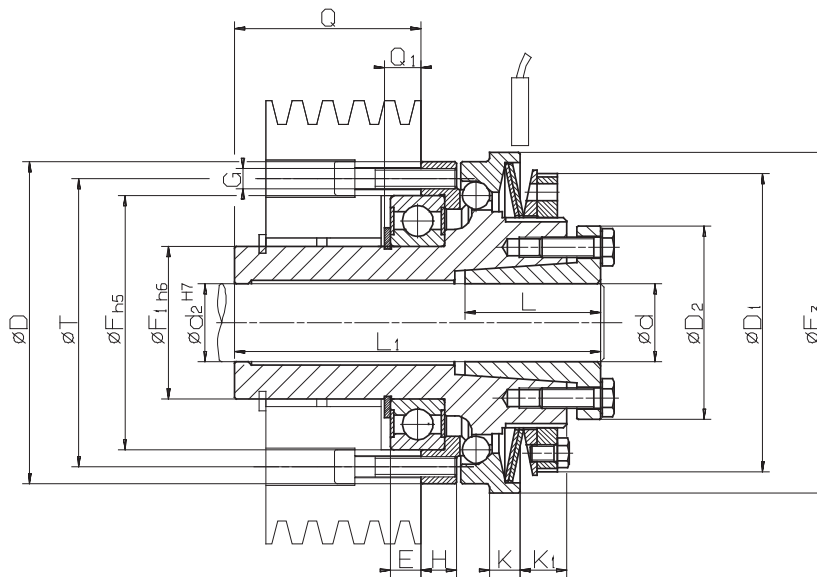

Z = number of tapped holes G on pitch circle T · Installation must be shut down as soon as torque limiter responds

41-1

Technical Data

Type	Art.-No.	Torque type 1			Torque type 2			Torque type 3		
		Limit torque Nm	max. speed min ⁻¹	End number	Limit torque Nm	max. speed min ⁻¹	End number	Limit torque Nm	max. speed min ⁻¹	End number
SUG 30.x	4479-125xxx	5 - 14	4000	101	10 - 28	4000	102	20 - 60	4000	103
SUG 40.x	4479-130xxx	9 - 27	3000	101	18 - 54	3000	102	38 - 115	3000	103
SUG 45.x	4479-140xxx	19 - 60	2500	101	38 - 125	2500	102	70 - 255	2500	103
SUG 55.x	4479-150xxx	35 - 110	2000	101	80 - 220	2000	102	160 - 440	2000	103
SUG 65.x	4479-160xxx	80 - 185	1200	101	160 - 370	1200	102	320 - 740	1200	103

Dimensions

Type	Art.-No.	Bore d*		D	D ₁	D ₂	E	F	F ₁	F ₃	G	H	K	K ₁	L	L ₁	Q	Q ₁	T	Z	Engage-ment travel mm
		min. mm	max. mm																		
SUG 30.x	4479-125xxx	10	20	65	63	40,5	5	47	30	70	M 4	7,5	7	12	26	72	33	6,5	56	8	1,2
SUG 30.x	4479-125xxx	19	25	65	63	42	5	47	30	70	M 4	7,5	7	12	26	72	33	6,5	56	8	1,2
SUG 40.x	4479-130xxx	15	30	80	77	57	7	62	40	85	M 5	8	8	12	31	88	43	8,75	71	8	1,5
SUG 45.x	4479-140xxx	19	30	95	88	57	9	75	45	100	M 6	10,5	9	14	40	108	55	11,5	85	8	1,8
SUG 45.x	4479-140xxx	32	40	95	88	64	9	75	45	100	M 6	10,5	9	14	31	108	55	11,5	85	8	1,8
SUG 55.x	4479-150xxx	32	50	110	100	73,5	10	90	55	115	M 6	12	10	16	29	124	67	13	100	8	2,0
SUG 65.x	4479-160xxx	32	50	130	122	73,5	10	100	65	135	M 8	12	12	21	29	140	73	14	116	8	2,2
SUG 65.x	4479-160xxx	55	60	130	122	89	10	100	65	135	M 8	12	12	21	45,5	141	73	14	116	8	2,2

Hub bore diameter d₂ is equal to the selected diameter d and serves as an additional centering guide.

*Available bore diameters d: 10, 11, 12, 14, 15, 16, 18, 19, 20, 22, 24, 25, 28, 30, 32, 35, 38, 40, 42, 45, 48, 50, 55 and 60 mm.

Example for Ordering

Type	Art.-No.	Preset limit torque	Bore d	with proximity switch
SUG 65. 1	4479-160 101	90 Nm	60 mm	See pages 62 and 63

└─┬─┘
Torque type

└─┬─┘
End number

with balls
flexible shaft coupling

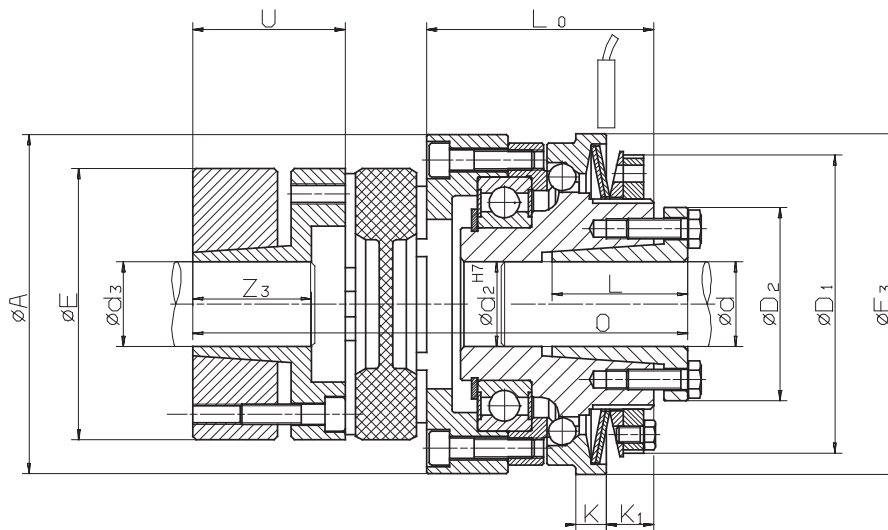

Installation must be shut down as soon as torque limiter responds

42-1

Technical Data

Type	Art.-No.	Torque type 1			Torque type 2			Torque type 3		
		Limit torque Nm	max. speed min ⁻¹	End number	Limit torque Nm	max. speed min ⁻¹	End number	Limit torque Nm	max. speed min ⁻¹	End number
SUE 30.x	4479-625xxx	5 - 14	4000	101	10 - 28	4000	102	20 - 60	4000	103
SUE 40.x	4479-630xxx	9 - 27	3000	101	18 - 54	3000	102	38 - 115	3000	103
SUE 45.x	4479-640xxx	19 - 60	2500	101	38 - 125	2500	102	70 - 255	2500	103
SUE 55.x	4479-650xxx	35 - 110	2000	101	80 - 220	2000	102	160 - 440	2000	103
SUE 65.x	4479-660xxx	80 - 185	1200	101	160 - 370	1200	102	320 - 740	1200	103

Dimensions

Type	Art.-No.	Bore d*		Bore d ₃ **		A	D ₁	D ₂	E	F ₃	K	K ₁	L	L ₀	O	U	Z ₃	Engage-ment travel
		min. mm	max. mm	min. mm	max. mm													
SUE 30.x	4479-625xxx	10	20	15	28	70	63	40,5	55	70	7	12	26	47	102	30	30	1,2
SUE 30.x	4479-625xxx	19	25	15	28	70	63	42	55	70	7	12	26	47	102	30	30	1,2
SUE 40.x	4479-630xxx	15	30	15	38	85	77	57	65	85	8	12	31	54,5	119,5	35	35	1,5
SUE 45.x	4479-640xxx	19	30	20	45	100	88	57	80	100	9	14	40	67	146	45	45	1,8
SUE 45.x	4479-640xxx	32	40	20	45	100	88	64	80	100	9	14	31	67	146	45	45	1,8
SUE 55.x	4479-650xxx	32	50	25	50	115	100	73,5	95	115	10	16	29	73	159	50	50	2,0
SUE 65.x	4479-660xxx	32	50	30	55	135	122	73,5	105	135	12	21	29	87	182	56	56	2,2
SUE 65.x	4479-660xxx	55	60	30	55	135	122	89	105	135	12	21	45,5	87	182	56	56	2,2

Hub bore diameter d₂ is equal to the selected diameter d and serves as an additional centering guide.

*Available bore diameters d: 10, 11, 12, 14, 15, 16, 18, 19, 20, 22, 24, 25, 28, 30, 32, 35, 38, 40, 42, 45, 48, 50, 55 and 60 mm.

**Available bore diameters d₃: 15, 16, 19, 20, 24, 25, 28, 30, 32, 35, 38, 40, 42, 45, 48, 50 and 55 mm.

Example for Ordering

Type	Art.-No.	Preset limit torque	Bore d	Bore d ₃	with proximity switch
SUE 30. 1	4479-625 101	10 Nm	12 mm	20 mm	See pages 62 and 63

└─┬─┘
Torque type

└─┬─┘
End number

with balls
with torsionally rigid shaft coupling

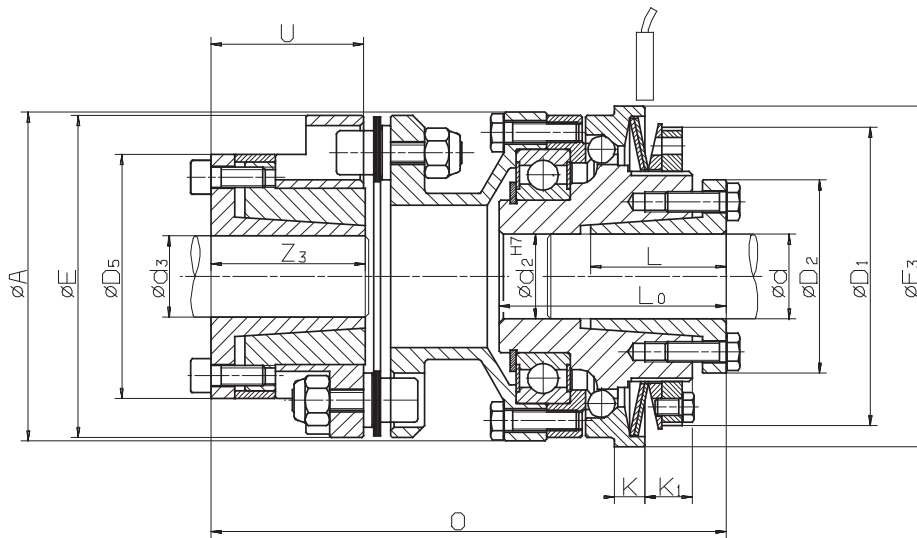

Installation must be shut down as soon as torque limiter responds

43-1

Technical Data

Type	Art.-No.	Torque type 1			Torque type 2			Torque type 3		
		Limit torque Nm	max. speed min ⁻¹	End number	Limit torque Nm	max. speed min ⁻¹	End number	Limit torque Nm	max. speed min ⁻¹	End number
SUL 30.x	4479-425xxx	5 - 14	4000	101	10 - 28	4000	102	20 - 60	4000	103
SUL 40.x	4479-430xxx	9 - 27	3000	101	18 - 54	3000	102	38 - 115	3000	103
SUL 45.x	4479-440xxx	19 - 60	2500	101	38 - 125	2500	102	70 - 255	2500	103
SUL 55.x	4479-450xxx	35 - 110	2000	101	80 - 220	2000	102	160 - 440	2000	103
SUL 65.x	4479-460xxx	80 - 185	1200	101	160 - 370	1200	102	320 - 740	1200	103

Dimensions

Type	Art.-No.	Bore d*		Bore d ₃ **		A	D ₁	D ₂	D ₅	E	F ₃	K	K ₁	L	L ₀	O	U	Z ₃	Engage-ment travel
		min. mm	max. mm	mm	mm	mm	mm	mm	mm	mm	mm	mm	mm	mm	mm	mm	mm	mm	mm
SUL 30.x	4479-425xxx	10	20	11	20	65	63	40,5	42	53	70	7	12	26	47	95,5	25,5	26,5	1,2
SUL 30.x	4479-425xxx	19	25	11	20	65	63	42	42	53	70	7	12	26	47	95,5	25,5	26,5	1,2
SUL 40.x	4479-430xxx	15	30	15	30	80	77	57	58	72	85	8	12	31	56	114,5	33	31	1,5
SUL 45.x	4479-440xxx	19	40	19	30	97	88	57	58	72	100	9	14	40	67	128	33	31	1,8
SUL 45.x	4479-440xxx	19	40	24	42	97	88	64	72	89	100	9	14	31	67	150	44,5	45	1,8
SUL 55.x	4479-450xxx	32	50	24	42	111	100	73,5	72	89	115	10	16	29	73	153,5	44,5	45	2,0
SUL 65.x	4479-460xxx	32	50	32	42	131	122	73,5	79	118	135	12	21	29	85	163,5	35	29	2,2
SUL 65.x	4479-460xxx	55	60	45	60	131	122	89	92	118	135	12	21	45,5	86	172,5	44	44	2,2

Hub bore diameter d₂ is equal to the selected diameter d and serves as an additional centering guide.

*Available bore diameters d: 10, 11, 12, 14, 15, 16, 18, 19, 20, 22, 24, 25, 28, 30, 32, 35, 38, 40, 42, 45, 48, 50, 55 and 60 mm.

**Available bore diameters d₃: 15, 16, 19, 20, 24, 25, 28, 30, 32, 35, 38, 40, 42, 45, 48, 50 and 55 mm.

Example for Ordering

Type	Art.-No.	Preset limit torque	Bore d	Bore d ₃	with proximity switch
SUL 55. 3	4479-450 103	420 Nm	45 mm	35 mm	See pages 62 and 63

└─┬─┘
Torque type

└─┬─┘
End number

Disengaging SIKUMAT® SR ...

with single rollers

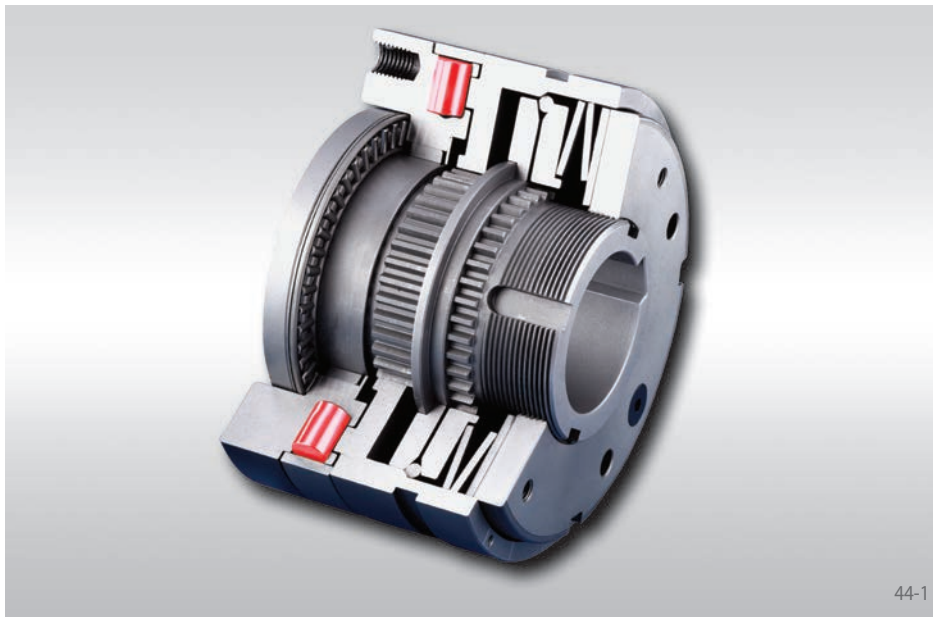

Advantages

- Disengages in case of overload – separation of input and output
- Integral fixed bearing
- Keyway in connecting flange for maximum torque capacity
- Calibrated micro adjustment of torque setting possible, even post-installation
- Cost effective

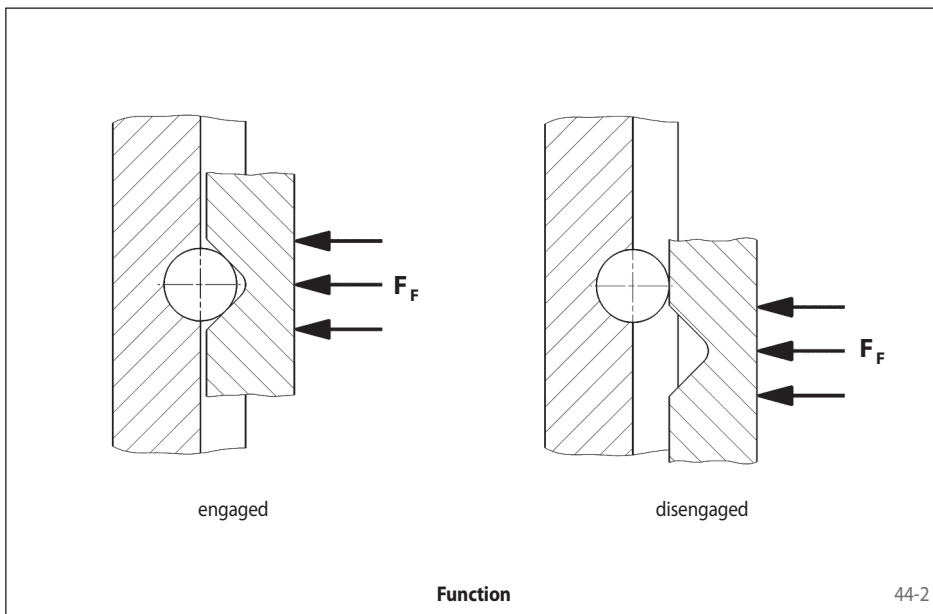

The Single Roller Principle

The torque is transmitted via rollers which are pressed into detents by Belleville springs. When the preset limit torque has been reached, the detent ring moves axially and the SIKUMAT® disengages. A locking mechanism holds the detent ring while it is in disengaged mode.

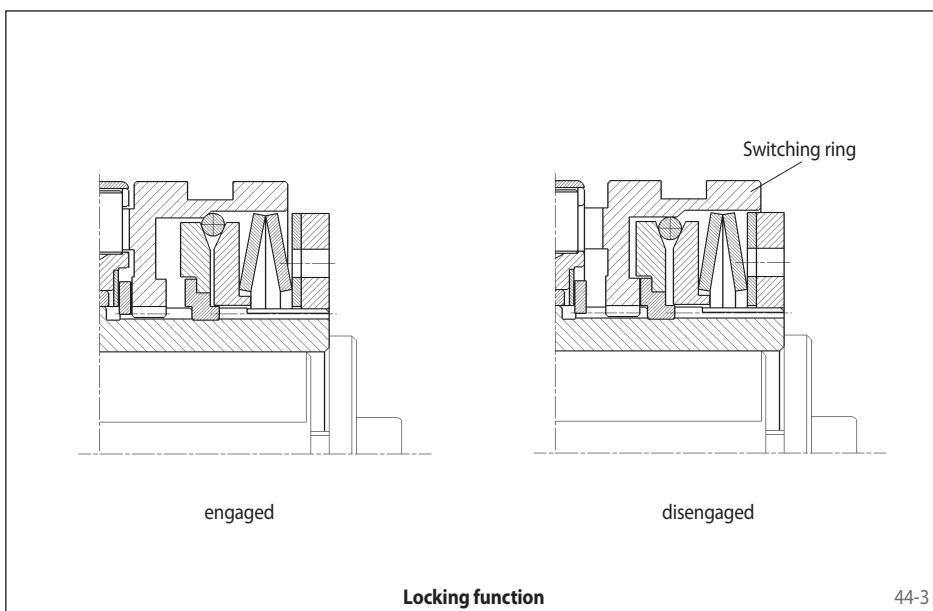

Function

- When the preset limit torque has been reached the SIKUMAT® disengages the input and output.
- After the overload has been eliminated the SIKUMAT® can be switched on again manually.
- This means that an axial switching force must be applied to the switching ring.

Types

Series SR - Basic version with flange connection

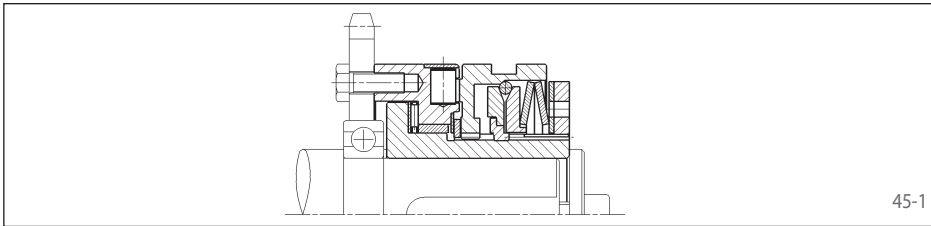

For attaching chain wheels, belt pulleys, gear wheels etc. Bearing of attached component on the shaft to be provided by the customer.

Page 46

Series SRR - with short hub and integral roller bearing

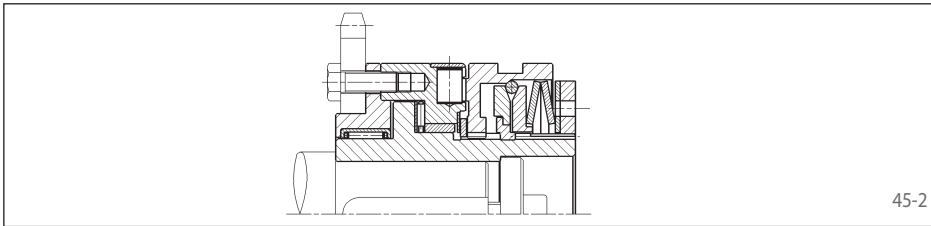

With short hub and needle bearing for narrow components to be connected.

Page 47

Series SRG - with long hub

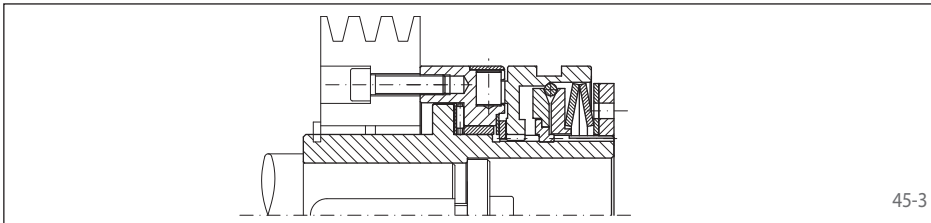

With long hub for wide components to be connected. Bearing of the attached component in the form of plain or needle bearing to be provided by the customer.

Page 48

Series SRE - with flexible shaft coupling

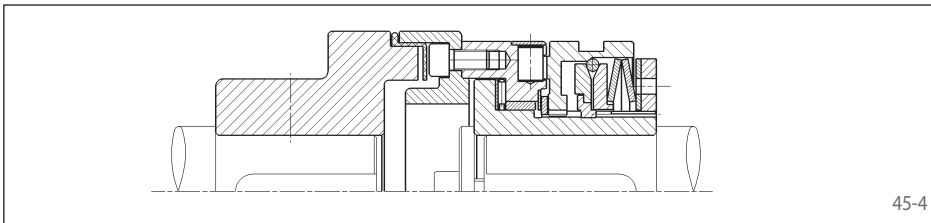

For flexible connection of two shafts. The flexible parts are oil-proof.

Page 49

Notes

Torque setting

The limit torque can be set at the factory on request. Setting or modification of the limit torque can also be carried out by the customer. See operating instructions for further details.

Proximity switch

The overload can be indicated by a non-contact or a mechanical proximity switch. Further details on pages 62 and 63.

with single rollers

Basic version with flange connection

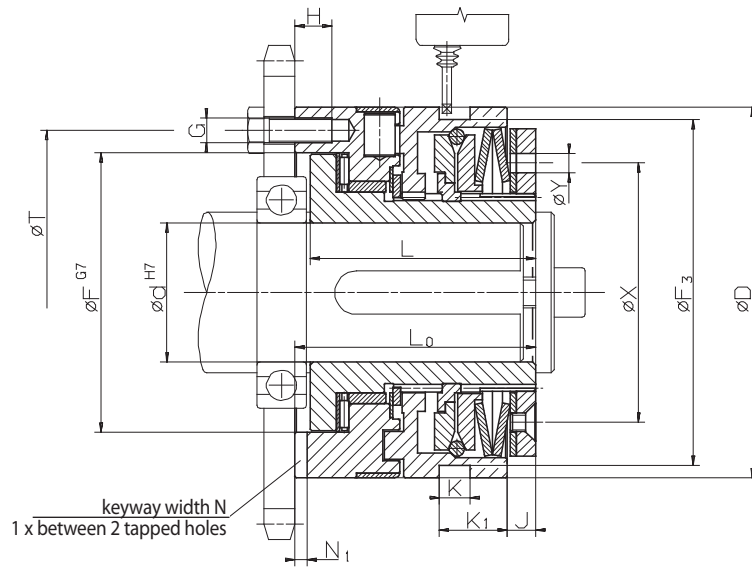

Z = number of tapped holes G on pitch circle T

46-1

Technical Data

Type	Art.-No.	Torque type 1			Torque type 2			Torque type 3		
		Limit torque Nm	max. speed min^{-1}	End number	Limit torque Nm	max. speed min^{-1}	End number	Limit torque Nm	max. speed min^{-1}	End number
SR 32.x	4470-020xxx	5 - 10	6000	601	10 - 20	6000	602	20 - 40	6000	603
SR 40.x	4470-025xxx	12 - 25	5000	601	25 - 50	5000	602	50 - 100	5000	603
SR 55.x	4470-035xxx	25 - 50	4000	601	50 - 100	4000	602	100 - 200	4000	603
SR 65.x	4470-045xxx	50 - 100	3500	601	100 - 200	3500	602	200 - 450	3500	603
SR 80.x	4470-055xxx	100 - 200	3000	601	200 - 400	3000	602	400 - 800	3000	603
SR 90.x	4470-065xxx	170 - 450	2300	601	350 - 900	2300	602	600 - 1800	2300	603

Dimensions

Type	Art.-No.	Bore d		D	F	F ₃	G	H	J	K	K ₁	L	L ₀	N	N ₁	T	X	Y	Z	Engage-ment travel mm
		min. mm	max. mm																	
SR 32.x	4470-020xxx	7	20	55	41	50	M 5	6,5	3	9	13,5	35	38,5	6	3,1	48	38,5	5	6	1,2
SR 40.x	4470-025xxx	10	25	82	60	72,5	M 5	8	6	9	14,5	48	52	6	3,1	70	54	6	6	1,8
SR 55.x	4470-035xxx	14	35	100	78	90,5	M 6	10	6	9	15	56	61	8	3,6	89	70	6	6	2,0
SR 65.x	4470-045xxx	18	45	120	90,5	112	M 8	12	8,5	10	22,5	72	78	10	4,1	105	84	6	6	2,2
SR 80.x	4470-055xxx	24	55	146	105	140	M 10	15	11	9	25	93,5	100	12	4,1	125	108	7	6	2,5
SR 90.x	4470-065xxx	30	70 ¹⁾	176	120,5	170	M 12	17	12	9	30	107	113,5	14	4,6	155	129	10	6	3,0

Keyway as per DIN 6885, page 1 · Tolerance of keyway width JS9

¹⁾ Keyway as per DIN 6885, page 3 · Tolerance of keyway width JS9

Example for Ordering

Type	Art.-No.	Preset limit torque	Bore d	with proximity switch
SR 40. 2	4470-025 602	30 Nm	21 mm	See pages 62 and 63

└─┬─┘
Torque type

└─┬─┘
End number

with single rollers
with short hub and integral needle bearing

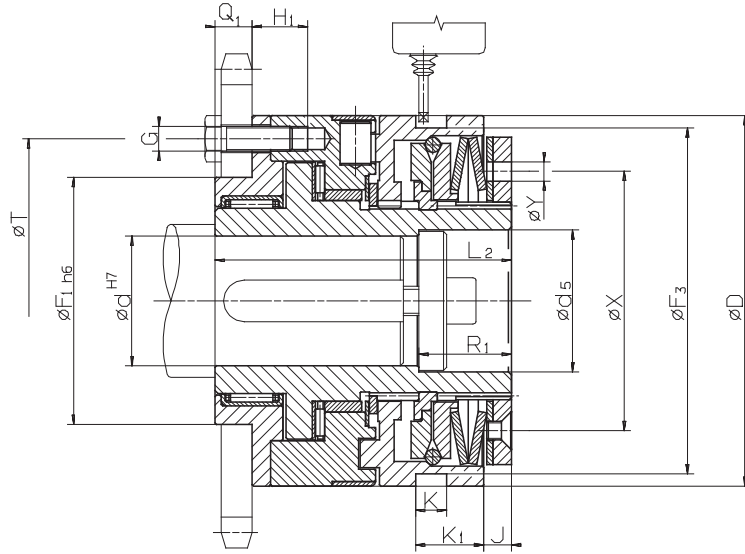

Z = number of tapped holes G on pitch circle T

47-1

Technical Data

Type	Art.-No.	Torque type 1			Torque type 2			Torque type 3		
		Limit torque Nm	max. speed min ⁻¹	End number	Limit torque Nm	max. speed min ⁻¹	End number	Limit torque Nm	max. speed min ⁻¹	End number
SRR 32.x	4470-920xxx	5 - 10	6000	601	10 - 20	6000	602	20 - 40	6000	603
SRR 40.x	4470-925xxx	12 - 25	5000	601	25 - 50	5000	602	50 - 100	5000	603
SRR 55.x	4470-935xxx	25 - 50	4000	601	50 - 100	4000	602	100 - 200	4000	603
SRR 65.x	4470-945xxx	50 - 100	3500	601	100 - 200	3500	602	200 - 450	3500	603
SRR 80.x	4470-955xxx	100 - 200	3000	601	200 - 400	3000	602	400 - 800	3000	603
SRR 90.x	4470-965xxx	170 - 450	2300	601	350 - 900	2300	602	600 - 1800	2300	603

Dimensions

Type	Art.-No.	Bore d		d ₅	D	F ₁	F ₃	G	H ₁	J	K	K ₁	L ₂	Q ₁	R ₁	T	X	Y	Z	Engage-ment travel mm
		min. mm	max. mm																	
SRR 32.x	4470-920xxx	7	20	21	55	38	50	M 5	11,5	3	9	13,5	51,5	8	15	48	38,5	5	6	1,2
SRR 40.x	4470-925xxx	10	25	26	82	50	72,5	M 5	16	6	9	14,5	70	10	20	70	54	6	6	1,8
SRR 55.x	4470-935xxx	14	35	36	100	60	90,5	M 6	15	6	9	15	78	12	25	89	70	6	6	2
SRR 65.x	4470-945xxx	18	45	46	120	80	112	M 8	18	8,5	10	22,5	96	12	30	105	84	6	6	2,2
SRR 80.x	4470-955xxx	24	55	56	146	100	140	M 10	23,5	11	9	25	124,5	16	30	125	108	7	6	2,5
SRR 90.x	4470-965xxx	30	70 ¹⁾	66	176	120	170	M 12	25,5	12	9	30	140	18	30	155	129	10	6	3

Keyway as per DIN 6885, page 1 · Tolerance of keyway width JS9

¹⁾ Keyway as per DIN 6885, page 3 · Tolerance of keyway width JS9

Example for Ordering

Type	Art.-No.	Preset limit torque	Bore d	with proximity switch
SRR 40. 2	4470-925 602	31 Nm	21 mm	See pages 62 and 63

└─┬─┘
Torque type

└─┬─┘
End number

with single rollers
with long hub

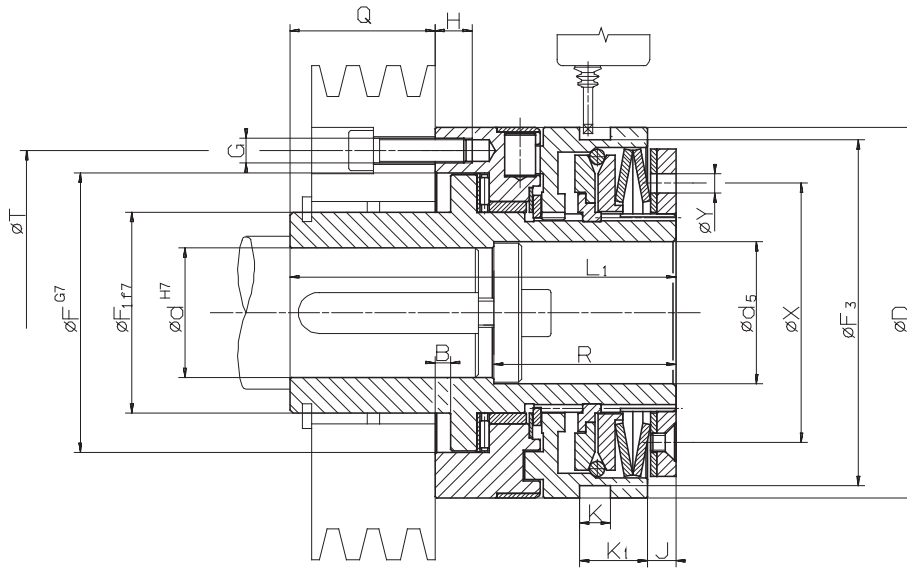

Z = number of tapped holes G on pitch circle T

48-1

Technical Data

Type	Art.-No.	Torque type 1			Torque type 2			Torque type 3		
		Limit torque Nm	max. speed min ⁻¹	End number	Limit torque Nm	max. speed min ⁻¹	End number	Limit torque Nm	max. speed min ⁻¹	End number
SRG 32.x	4470-120xxx	5 - 10	6000	601	10 - 20	6000	602	20 - 40	6000	603
SRG 40.x	4470-125xxx	12 - 25	5000	601	25 - 50	5000	602	50 - 100	5000	603
SRG 55.x	4470-135xxx	25 - 50	4000	601	50 - 100	4000	602	100 - 200	4000	603
SRG 65.x	4470-145xxx	50 - 100	3500	601	100 - 200	3500	602	200 - 450	3500	603
SRG 80.x	4470-155xxx	100 - 200	3000	601	200 - 400	3000	602	400 - 800	3000	603
SRG 90.x	4470-165xxx	170 - 450	2300	601	350 - 900	2300	602	600 - 1800	2300	603

Dimensions

Type	Art.-No.	Bore d		d ₅	B	D	F	F ₁	F ₃	G	H	J	K	K ₁	L ₁	Q	R	T	X	Y	Z	Engage-ment travel mm	
		min. mm	max. mm																				
SRG 32.x	4470-120xxx	7	20	21	4	55	41	28	50	M 5	6,5	3	9	13,5	66	27,5	25,5	48	38,5	5	6	6	1,2
SRG 40.x	4470-125xxx	10	25	26	4	82	60	38	72,5	M 5	8	6	9	14,5	83	33	35	70	54	6	6	6	1,8
SRG 55.x	4470-135xxx	14	35	36	5	100	78	52	90,5	M 6	10	6	9	15	100	39	45	89	70	6	6	6	2,0
SRG 65.x	4470-145xxx	18	45	46	5	120	90,5	65	112	M 8	12	8,5	10	22,5	125	47	59	105	84	6	6	6	2,2
SRG 80.x	4470-155xxx	24	55	56	6,5	146	105	78	140	M 10	15	11	9	25	152,5	52,5	60	125	108	7	6	6	2,5
SRG 90.x	4470-165xxx	30	70 ¹⁾	66	6,5	176	120,5	90	170	M 12	17	12	9	30	171	57,5	60	155	129	10	6	6	3,0

Keyway as per DIN 6885, page 1 · Tolerance of keyway width JS9

¹⁾ Keyway as per DIN 6885, page 3 · Tolerance of keyway width JS9

Example for Ordering

Type	Art.-No.	Preset limit torque	Bore d	with proximity switch
SRG 40. 2	4470-125 602	30 Nm	21 mm	See pages 62 and 63

└─┬─┘
Torque type

└─┬─┘
End number

with single rollers
with flexible shaft coupling

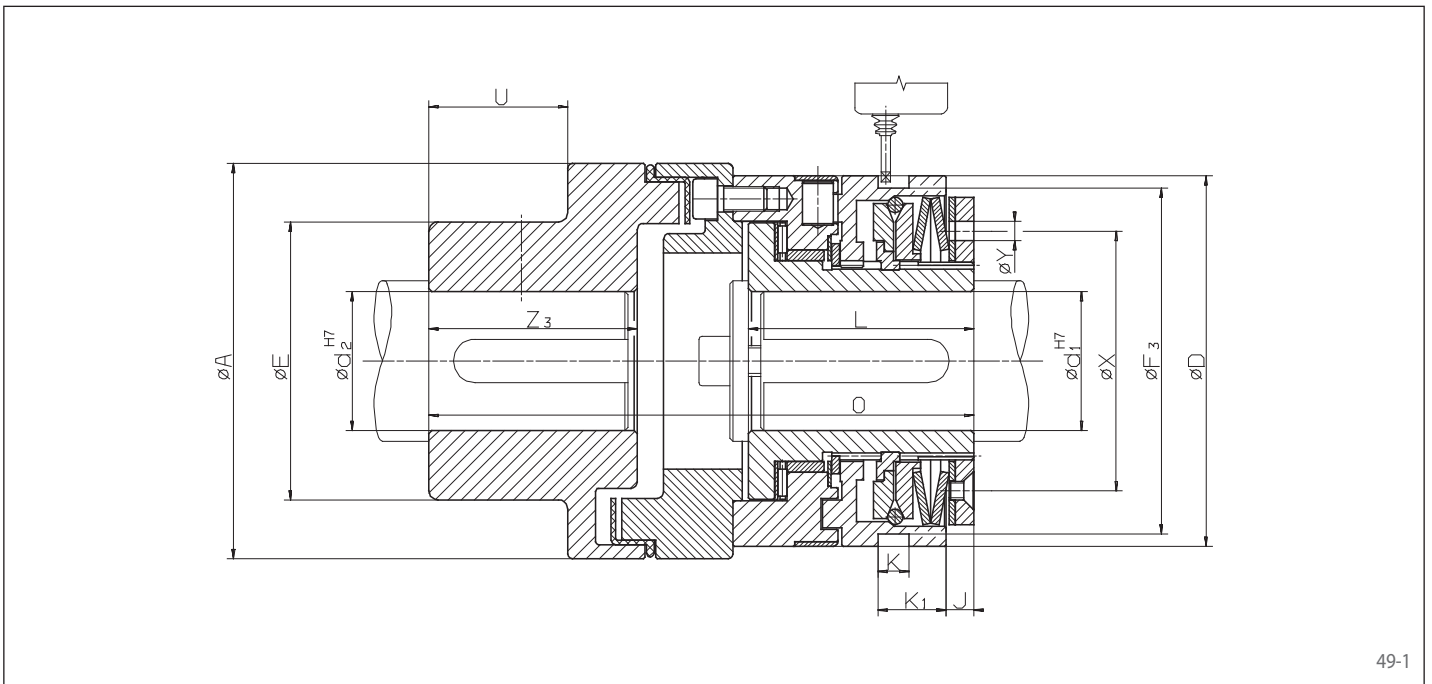

49-1

Technical Data

Type	Art.-No.	Torque type 1			Torque type 2			Torque type 3		
		Limit torque Nm	max. speed min ⁻¹	End number	Limit torque Nm	max. speed min ⁻¹	End number	Limit torque Nm	max. speed min ⁻¹	End number
SRE 32.x	4470-620xxx	5 - 10	6000	601	10 - 20	6000	602	20 - 40	6000	603
SRE 40.x	4470-625xxx	12 - 25	5000	601	25 - 50	5000	602	50 - 100	5000	603
SRE 55.x	4470-635xxx	25 - 50	4000	601	50 - 100	4000	602	100 - 200	4000	603
SRE 65.x	4470-645xxx	50 - 100	3500	601	100 - 200	3500	602	200 - 450	3500	603
SRE 80.x	4470-655xxx	100 - 200	3000	601	200 - 400	3000	602	400 - 800	3000	603
SRE 90.x	4470-665xxx	170 - 450	2300	601	350 - 900	2300	602	600 - 1800	2300	603

Dimensions

Type	Art.-No.	Bore d ₁		d ₂ max. mm	A mm	E mm	D mm	F ₃ mm	J mm	K mm	K ₁ mm	L mm	O mm	U mm	X mm	Y mm	Z ₃ mm	Engage- ment travel mm
		min. mm	max. mm															
SRE 32.x	4470-620xxx	7	20	30	67	46	55	50	3	9	13,5	35	86	15	38,5	5	28	1,6
SRE 40.x	4470-625xxx	10	25	50	112	79	82	72,5	6	9	14,5	48	137,5	38	54	6	58	2,3
SRE 55.x	4470-635xxx	14	35	50	112	79	100	90,5	6	9	15	56	147	38	70	6	58	3,0
SRE 65.x	4470-645xxx	18	45	60	128	90	120	112	8,5	10	22,5	72	176,5	45	84	6	67	3,5
SRE 80.x	4470-655xxx	24	55	60	148	90	146	140	11	9	25	93,5	211,5	45	108	7	67	3,8
SRE 90.x	4470-665xxx	30	70 ¹⁾	70	177	107	176	170	12	9	30	107	242,5	52	129	10	75	4,5
SRE 90.3	4470-665xxx	30	70 ¹⁾	90	198	140	176	170	12	9	30	107	272	52	129	10	75	4,5

Keyway as per DIN 6885, page 1 · Tolerance of keyway width JS9

¹⁾ Keyway as per DIN 6885, page 3 · Tolerance of keyway width JS9

Example for Ordering

Type	Art.-No.	Preset limit torque	Bore d ₁	Bore d ₂	with proximity switch
SRE 40. 2	4470-625 602	35 Nm	21 mm	35 mm	See pages 62 and 63

Torque type

End number

Synchronous Disengaging SIKUMAT® SB ...

with double rollers

RINGSPANN®

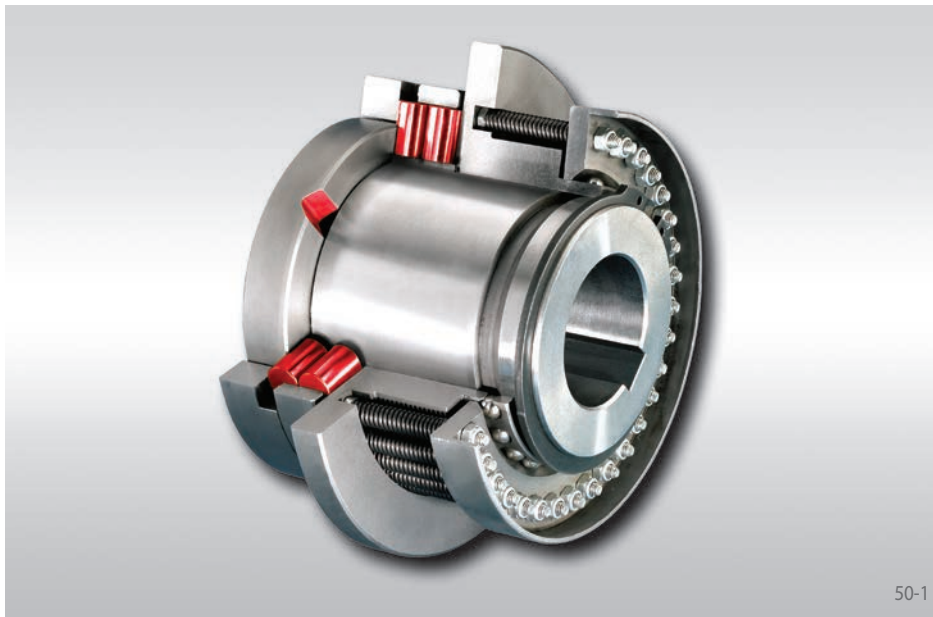

Advantages

- High degree of consistency of limit torque over the duration of operation through double roller principle
- Switching off in case of overload – separation of input and output
- Synchronous re-engagement after 360°
- Torques up to 10 000 Nm
- For shaft diameters up to 125 mm

The Double Roller Principle

The torque is transmitted via six pairs of rollers which are pressed by coil springs into detents. When the preset limit torque has been reached, the rollers move against the spring force up the sloping surface and disengage. This characteristic combined with the particular geometry of the detents provide a high degree of consistency to the limit torque of the SIKUMAT® over the duration of the operating period. Re-engagement is effected synchronously after 360° due to the asymmetrical division of the detents.

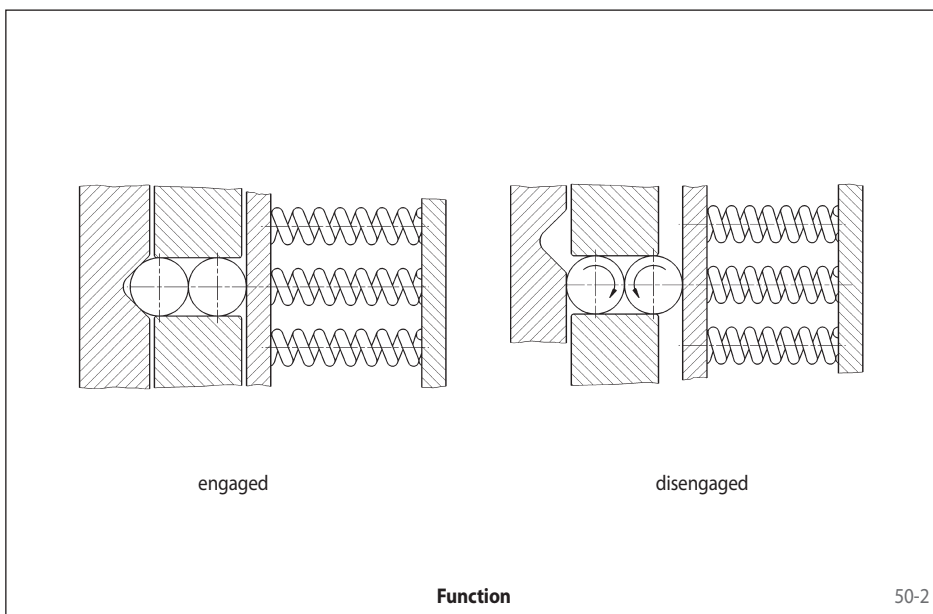

Function

- When the preset limit torque has been reached the SIKUMAT® effects a separation of input and output by means of a locking mechanism with integral bearings.
- Following elimination of the overload manual synchronous re-engagement of the SIKUMAT® to the starting position after 360°.
- This requires an axial switching force to be applied to the switching ring.

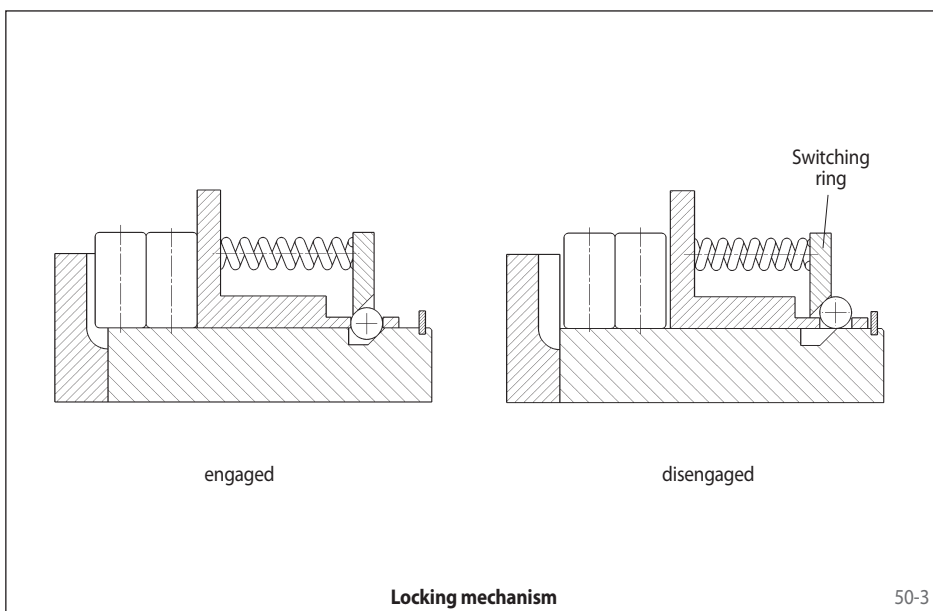

Types

Series SB - Basic version with flange connection

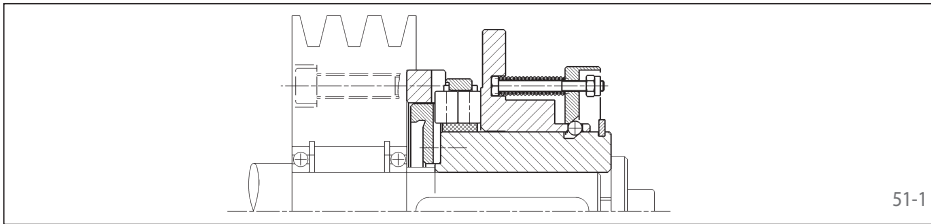

For attaching chain wheels, belt pulleys, gear wheels etc. Bearing of attached component on the shaft to be provided by the customer.

Page 52

Series SBG - with long hub

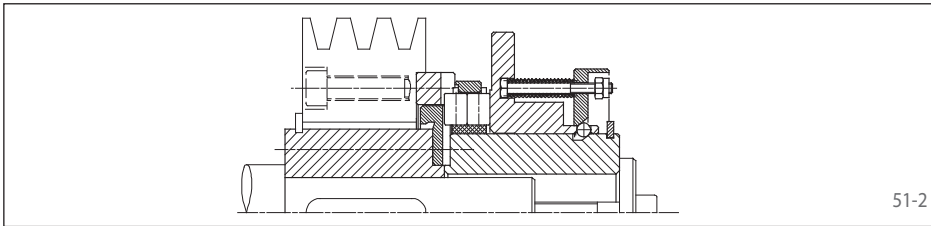

With long hub for wide connecting parts. Delivery includes plain bearing.

Page 53

Series SBE - with flexible shaft coupling

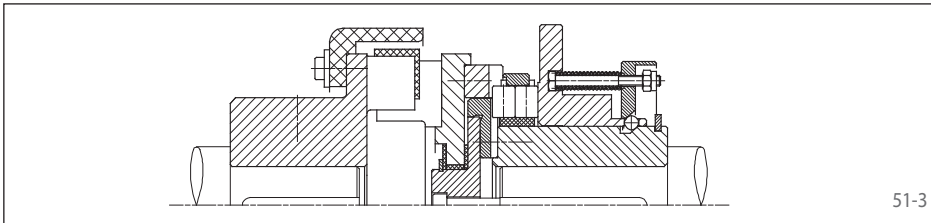

For flexible connection of two shafts. The flexible parts are oil-proof.

Page 54

Series SBL - with torsionally rigid shaft coupling

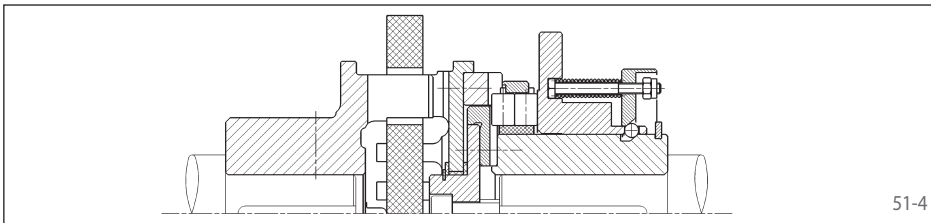

For torsionally rigid connection of two shafts. Possibility to compensate for large radial and angular displacements.

Page 55

Notes

Torque setting

Normally the limit torque is set at the factory. Setting or modification of the limit torque can be carried out by the customer but no unauthorised adjustment should be made by the machine operator. See operating instructions for further details.

Proximity switch

The overload can be indicated by a non-contact or a mechanical proximity switch. Further details on pages 62 and 63.

with double rollers

Basic version with flange connection

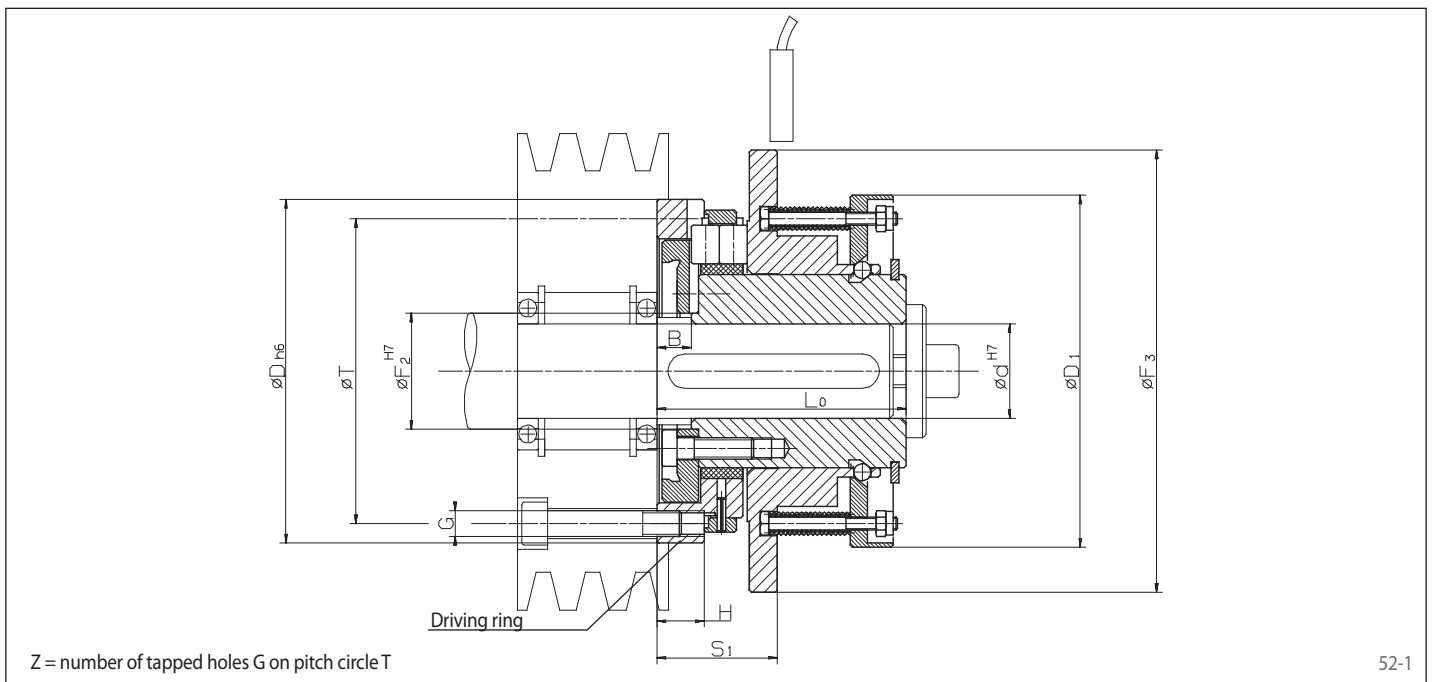

Technical Data

Type	Art.-No.	Limit torque	max. speed
		Nm	min ⁻¹
SB 4	4470-004900	8 - 80	6000
SB 7	4470-007900	26 - 310	3800
SB 11	4470-011900	105 - 1250	2500
SB 14	4470-014900	210 - 2500	2100
SB 18	4470-018900	420 - 5000	1700
SB 22	4470-022900	840 - 10000	1300

Dimensions

Type	Art.-No.	Bore d		B	D	D ₁	F ₂	F ₃	G	H	L ₀	S ₁	T	Z	Engage-ment travel
		min. mm	max. mm												
SB 4	4470-004900	9	25	8	80	82	27	103	M 6	11	58	28	71	3	1,6
SB 7	4470-007900	25	40	10	125	125	43	150	M 8	19	90	43	109	3	2,5
SB 11	4470-011900	30	65	15	180	185	75	224	M 10	16	140	69	160	6	4,0
SB 14	4470-014900	50	80	20	224	224	95	272	M 12	18	180	87	200	6	5,0
SB 18	4470-018900	65	100	24	280	280	118	335	M 16	25	224	110	250	6	6,2
SB 22	4470-022900	80	125	30	355	355	150	412	M 20	30	280	140	315	6	8,0

Keyway as per DIN 6885, page 1 · Tolerance of keyway width P9

Example for Ordering

Type	Art.-No.	Preset limit torque	Bore d	with proximity switch
SB 4	4470-004 900	15 Nm	20 mm	See pages 62 and 63

with double rollers
with long hub

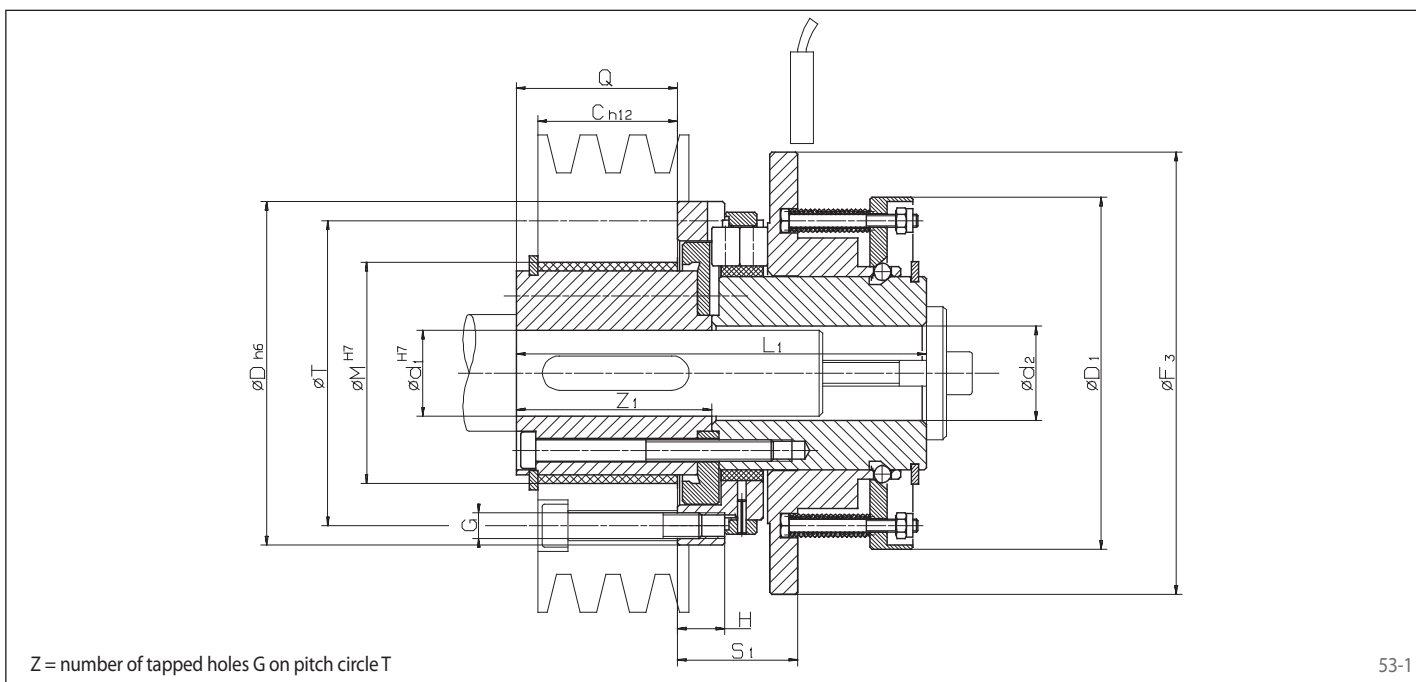

Technical Data

Type	Art.-No.	Limit torque	max. speed
		Nm	min ⁻¹
SBG 4	4470-104900	8 - 80	6000
SBG 7	4470-107900	26 - 310	3800
SBG 11	4470-111900	105 - 1250	2500
SBG 14	4470-114900	210 - 2500	2100

Dimensions

Type	Art.-No.	Bore d ₁		C	D	D ₁	F ₃	G	H	L ₁	M	Q	S ₁	T	Z	Z ₁	Engage-ment travel
		min. mm	max. mm														
SBG 4	4470-104900	9	25	25	80	82	103	M 6	11	103	55	32	24	71	3	39	1,6
SBG 7	4470-107900	25	40	40	125	125	150	M 8	19	155	80	46	38	109	3	55	2,5
SBG 11	4470-111900	40	65	63	180	185	224	M 10	16	250	120	75	61	160	6	87	4,0
SBG 14	4470-114900	50	80	80	224	224	272	M 12	18	275	155	95	87	200	6	109	5,0

Bore d₂ is 0,2...0,5 mm larger than d₁ for sizes 4 – 7

Bore d₂ is 0,5...1,0 mm larger than d₁ for sizes 11 – 14

Keyway as per DIN 6885, page 1 · Tolerance of keyway width P9

Example for Ordering

Type	Art.-No.	Preset limit torque	Bore d ₁	with proximity switch
SBG 4	4470-104 900	15 Nm	18 mm	See pages 62 and 63

Synchronous Disengaging SIKUMAT® SBE

with double rollers
with flexible shaft coupling

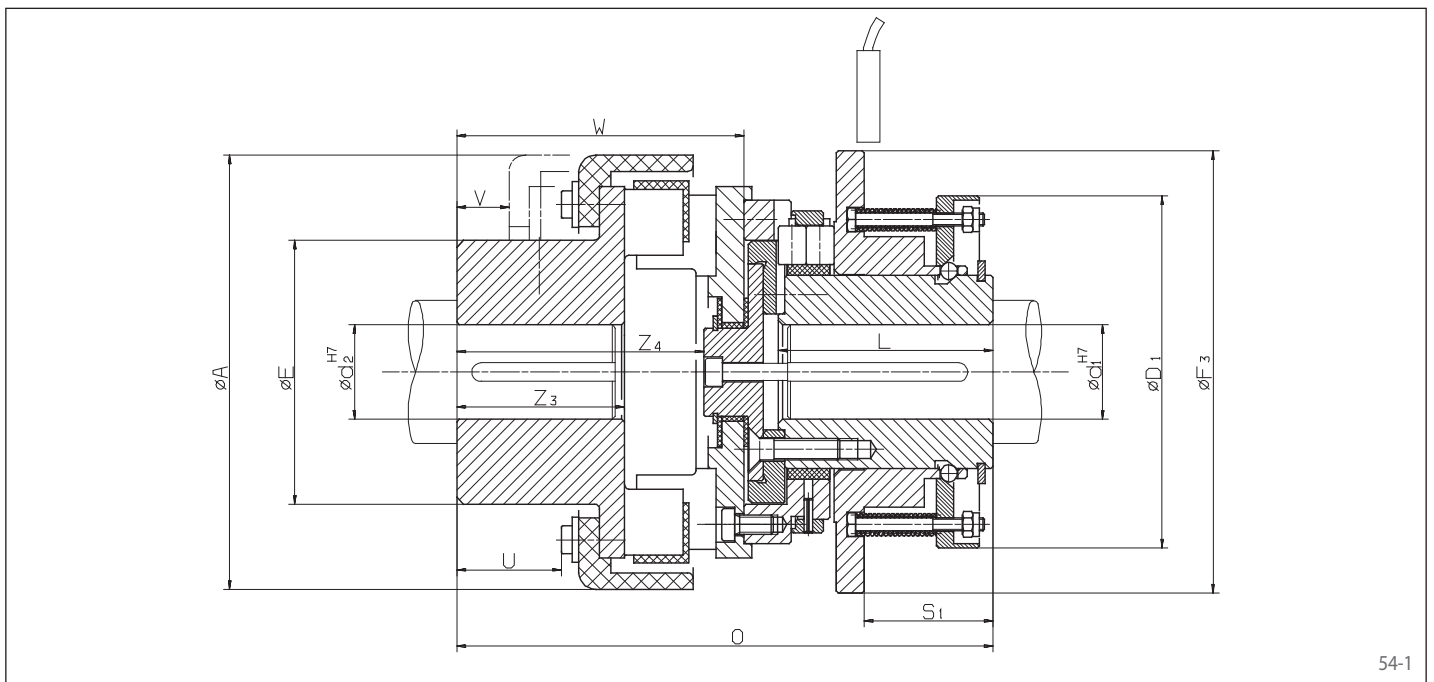

Technical Data

Type	Art.-No.	Limit torque	max. speed
		Nm	min ⁻¹
SBE 4	4470-604900	8 - 80	6000
SBE 7	4470-607900	26 - 310	3800
SBE 11	4470-611900	105 - 1250	2500
SBE 14	4470-614900	210 - 2500	2100
SBE 18	4470-618900	420 - 5000	1700
SBE 22	4470-622900	840 - 10000	1300

Dimensions

Type	Art.-No.	Bore d ₁		Bore d ₂		A	D ₁	F ₃	E	L	O	S ₁	U	V	W	Z ₃	Z ₄	Engage-ment travel
		min. mm	max. mm	min. mm	max. mm													
SBE 4	4470-604900	9	25	5	45	114	82	103	72	50	133	30	28	19	75	41	63	1,6
SBE 7	4470-607900	25	40	20	60	158	125	150	96	80	202	47	39	21	112	61	97	2,5
SBE 11	4470-611900	30	65	25	80	230	185	224	130	125	283	71	49	21	143	82	124	4,0
SBE 14	4470-614900	50	80	45	100	294	224	272	160	160	359	93	56	17	179	97	153	5,0
SBE 18	4470-618900	65	100	60	120	330	280	335	195	200	430	114	80	25	206	116	179	6,2
SBE 22	4470-622900	80	125	75	160	432	355	412	255	250	563	140	104	31	283	160	247	8,0

Keyway as per DIN 6885, page 1 · Tolerance of keyway width P9

Example for Ordering

Type	Art.-No.	Preset limit torque	Bore d ₁	Bore d ₂	with proximity switch
SBE 4	4470-604 900	15 Nm	14 mm	30 mm	See pages 62 and 63

with double rollers
with torsionally rigid shaft coupling

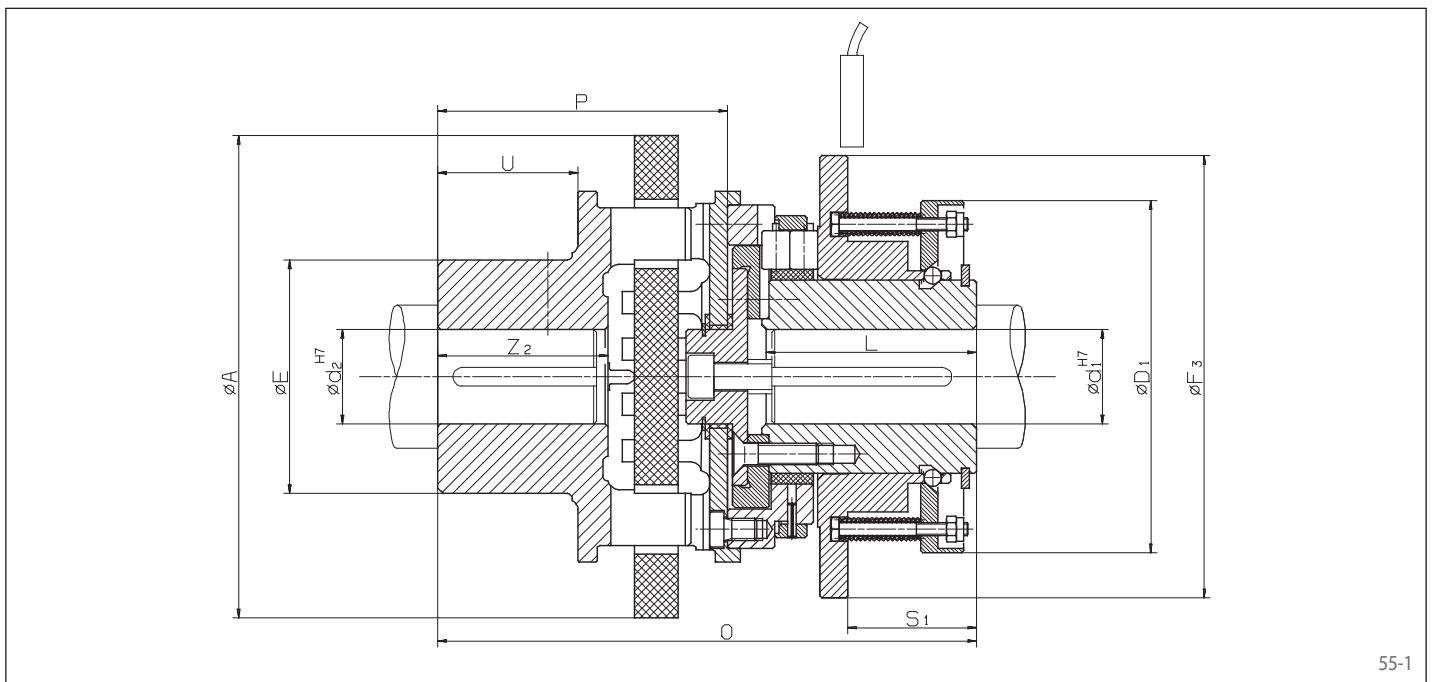

55-1

Technical Data

Type	Art.-No.	Limit torque	max. speed
		Nm	min ⁻¹
SBL 4	4470-404900	8 - 80	4100
SBL 7	4470-407900	26 - 310	2670
SBL 11	4470-411900	105 - 1250	1700
SBL 14	4470-414900	210 - 2500	1350
SBL 18	4470-418900	420 - 5000	1350
SBL 22	4470-422900	840 - 10000	1050

Dimensions

Type	Art.-No.	Bore d ₁		Bore d ₂		A	D ₁	E	F ₃	L	O	P	U	S ₁	Z ₂	Engage-ment travel
		min. mm	max. mm	min. mm	max. mm											
SBL 4	4470-404900	9	25	16	35	110	82	53	103	50	135	77	33	30	42	1,6
SBL 7	4470-407900	25	40	30	50	160	125	85	150	80	195	105	51	47	62	2,5
SBL 11	4470-411900	30	65	50	90	250	185	150	224	125	300	160	81	71	100	4,0
SBL 14	4470-414900	50	80	60	110	315	224	175	272	160	384	204	101	93	124	5,0
SBL 18	4470-418900	65	100	60	110	315	280	175	335	200	462	238	101	114	124	6,2
SBL 22	4470-422900	80	125	75	140	400	355	216	412	250	600	320	130	140	160	8,0

Permissible radial displacement 0,015 x ø A · Permissible angular displacement max. 3°
Keyway as per DIN 6885, page 1 · Tolerance of keyway width P9

Example for Ordering

Type	Art.-No.	Preset limit torque	Bore d ₁	Bore d ₂	with proximity switch
SBL 4	4470-404 900	23 Nm	11 mm	21 mm	See pages 62 and 63

Non-disengaging SIKUMAT® SL ...

with single rollers

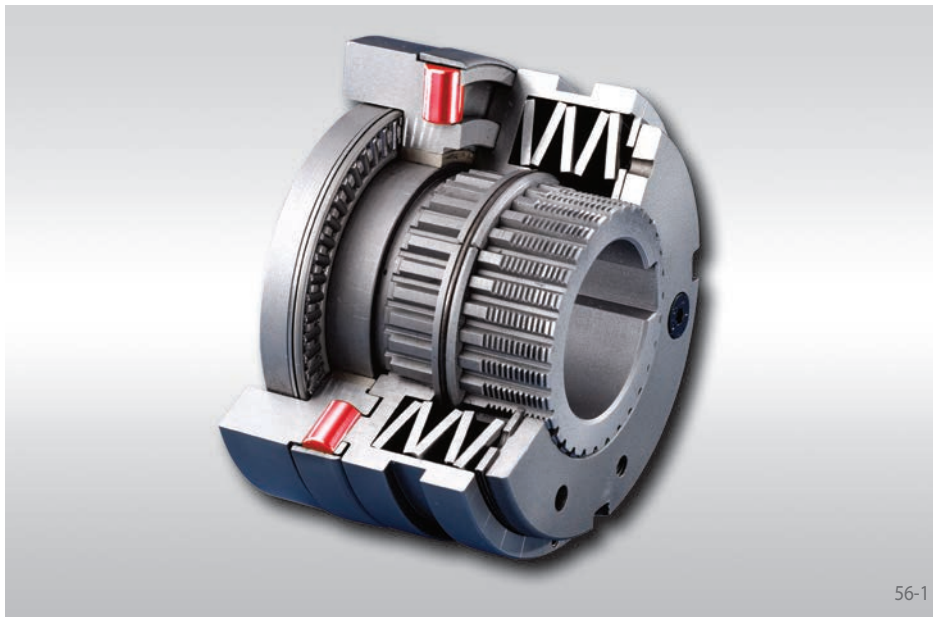

Advantages

- Output is fully driven even in case of overload
- Integral fixed bearing
- Driving keyway in the connecting flange for maximum torque capacity
- Calibrated micro adjustment of torque setting possible, even post-installation
- Cost effective

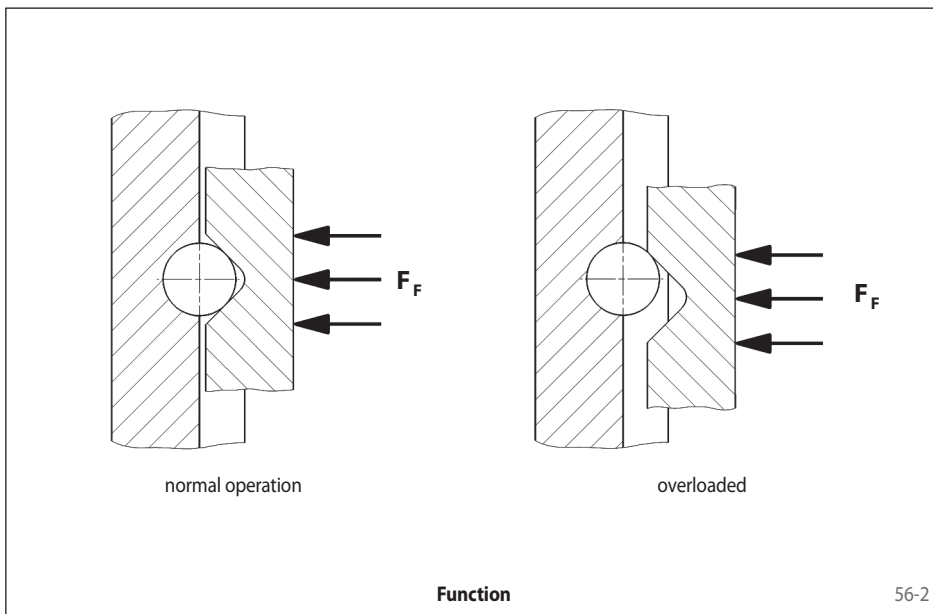

The Single Roller Principle

The torque is transmitted via rollers which are pressed by Belleville springs into detents. When the preset limit torque has been reached, the detent ring is displaced but is prevented by its particular design from disengaging completely. There is therefore no disengaging of input and output.

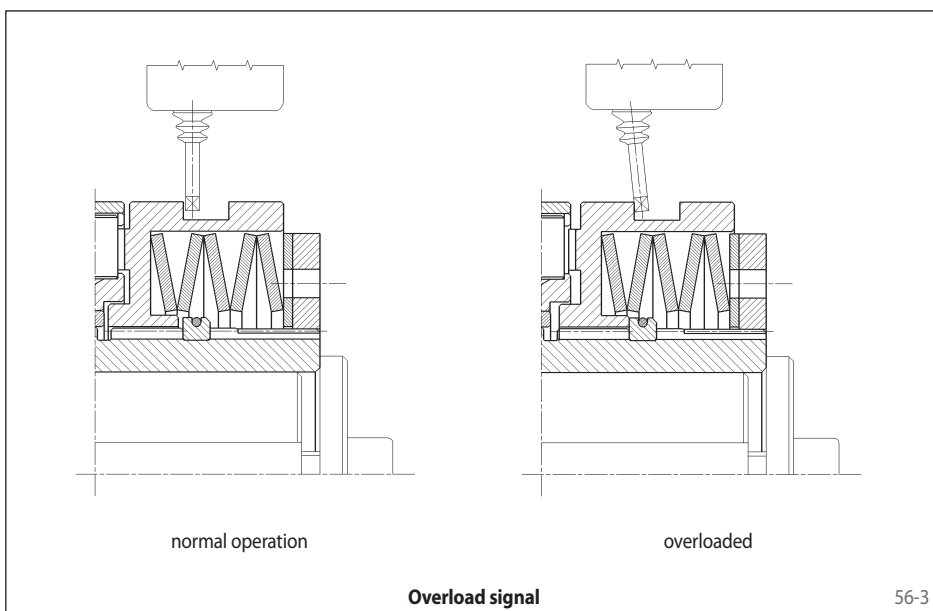

Function

- When the preset limit torque has been reached, a limit sensor indicates the overload.
- There is no interruption of torque transmission between drive and output.

Types

Series SL - Basic version with flange connection

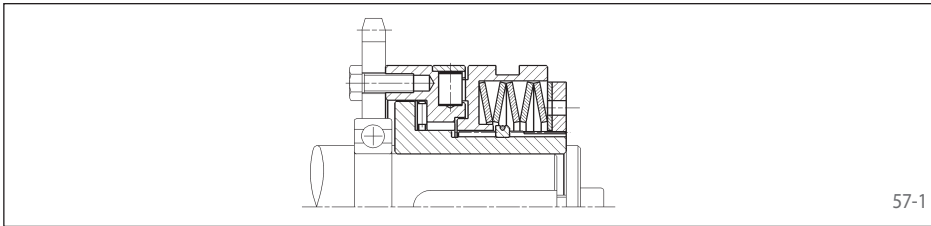

For attaching chain wheels, belt pulleys, gear wheels etc. Bearing of attached component on the shaft to be provided by the customer.

Page 58

Series SLR - with short hub and integral needle bearing

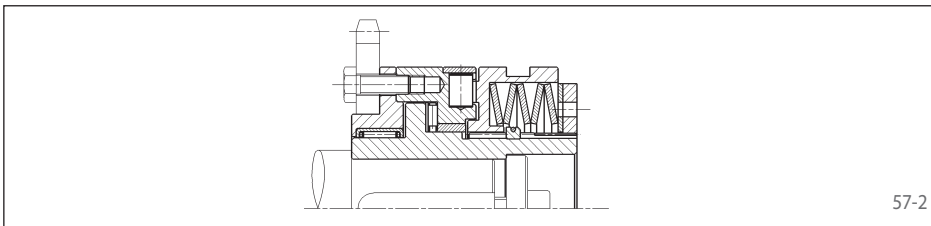

With short hub and needle bearing for narrow components to be connected.

Page 59

Series SLG - with long hub

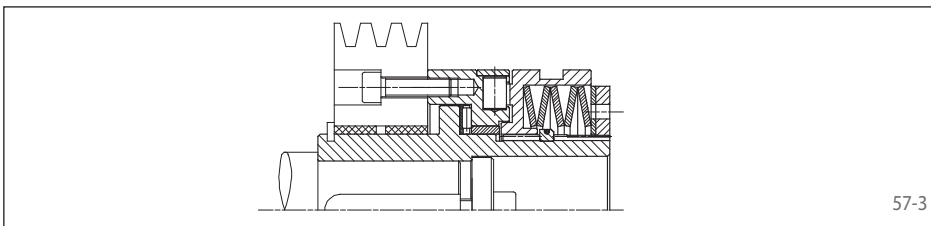

With long hub for wide components to be connected. Bearing of the attached component in the form of plain or needle bearing to be provided by the customer.

Page 60

Series SLE - with flexible shaft coupling

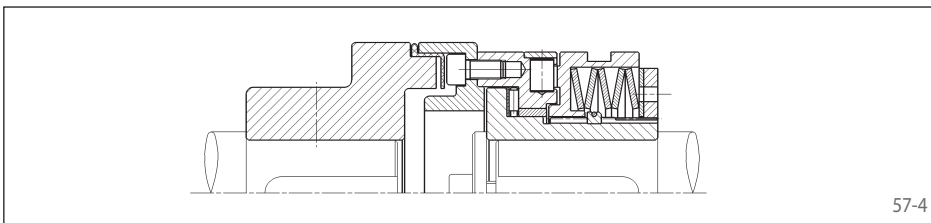

For flexible connection of two shafts. Possibility to compensate for large radial and angular displacements.

Page 61

Notes

Torque setting

The limit torque can be set at the factory on request. Setting or modification of the limit torque can also be carried out by the customer. See operating instructions for further details.

Proximity switch

The overload can be indicated by a non-contact or a mechanical proximity switch. Further details on pages 62 and 63.

with single rollers

Basic version with flange connection

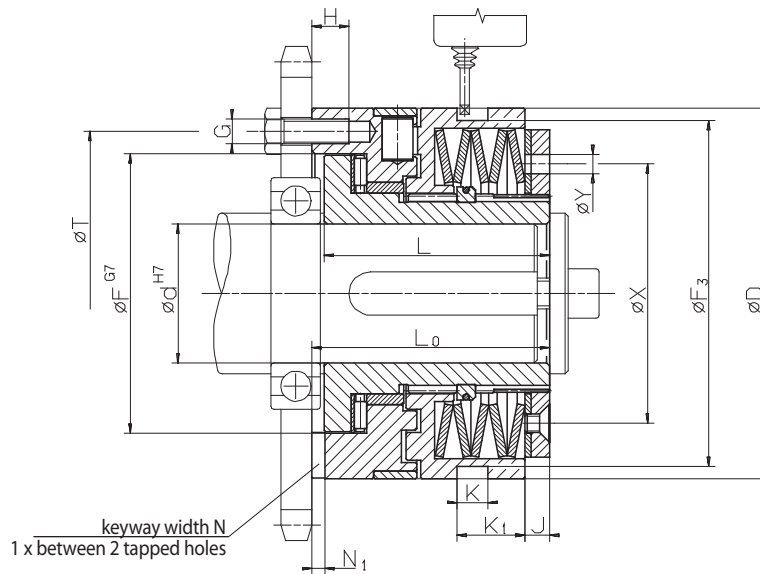

Z = number of tapped holes G on pitch circle T

58-1

Technical Data

Type	Art.-No.	Torque type 1			Torque type 2			Torque type 3		
		Limit torque Nm	max. speed min^{-1}	End number	Limit torque Nm	max. speed min^{-1}	End number	Limit torque Nm	max. speed min^{-1}	End number
SL 32.x	4470-020xxx	5 - 10	4000	701	10 - 20	4000	702	20 - 40	3000	703
SL 40.x	4470-025xxx	12 - 25	3900	701	25 - 50	3900	702	50 - 100	2900	703
SL 55.x	4470-035xxx	25 - 50	3300	701	50 - 100	3300	702	100 - 200	2400	703
SL 65.x	4470-045xxx	50 - 100	2800	701	100 - 200	2800	702	200 - 450	2000	703
SL 80.x	4470-055xxx	100 - 200	2300	701	200 - 400	2300	702	400 - 800	1600	703
SL 90.x	4470-065xxx	170 - 450	1800	701	350 - 900	1800	702	600 - 1800	1400	703

Dimensions

Type	Art.-No.	Bore d		D	F	F ₃	G	H	J	K	K ₁	L	L ₀	N	N ₁	T	X	Y	Z	Engage-ment travel
		min. mm	max. mm																	
SL 32.x	4470-020xxx	7	20	55	41	50	M 5	6,5	3	9	13,5	35	38,5	6	3,1	48	38,5	5	6	0,6
SL 40.x	4470-025xxx	10	25	82	60	72,5	M 5	8	6	9	14,5	48	52	6	3,1	70	54	6	6	0,8
SL 55.x	4470-035xxx	14	35	100	78	90,5	M 6	10	6	9	15	56	61	8	3,6	89	70	6	6	1,1
SL 65.x	4470-045xxx	18	45	120	90,5	112	M 8	12	8,5	10	22,5	72	78	10	4,1	105	84	6	6	1,2
SL 80.x	4470-055xxx	24	55	146	105	140	M 10	15	11	9	25	93,5	100	12	4,1	125	108	7	6	1,2
SL 90.x	4470-065xxx	30	70 ¹⁾	176	120,5	170	M 12	17	12	9	30	107	113,5	14	4,6	155	129	10	6	1,6

Keyway as per DIN 6885, page 1 · Tolerance of keyway width JS9

¹⁾ Keyway as per DIN 6885, page 3 · Tolerance of keyway width JS9

Example for Ordering

Type	Art.-No.	Preset limit torque	Bore d	with proximity switch
SL 32. 1	4470-020 701	9 Nm	14 mm	See pages 62 and 63

└─┬─┘
Torque type

└─┬─┘
End number

Non-disengaging SIKUMAT® SLR

with single rollers
with short hub and integral needle bearing

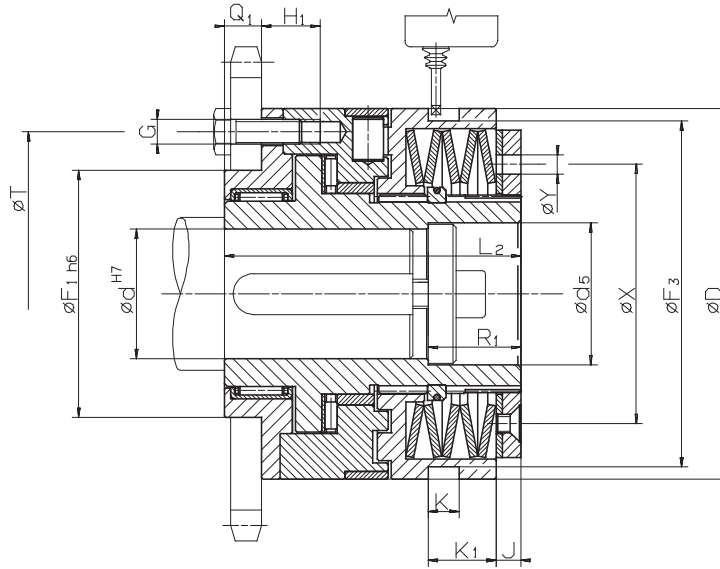

Z = number of tapped holes G on pitch circle T

59-1

Technical Data

Type	Art.-No.	Torque type 1			Torque type 2			Torque type 3		
		Limit torque Nm	max. speed min ⁻¹	End number	Limit torque Nm	max. speed min ⁻¹	End number	Limit torque Nm	max. speed min ⁻¹	End number
SLR 32.x	4470-920xxx	5 - 10	4000	701	10 - 20	4000	702	20 - 40	3000	703
SLR 40.x	4470-925xxx	12 - 25	3900	701	25 - 50	3900	702	50 - 100	2900	703
SLR 55.x	4470-935xxx	25 - 50	3300	701	50 - 100	3300	702	100 - 200	2400	703
SLR 65.x	4470-945xxx	50 - 100	2800	701	100 - 200	2800	702	200 - 450	2000	703
SLR 80.x	4470-955xxx	100 - 200	2300	701	200 - 400	2300	702	400 - 800	1600	703
SLR 90.x	4470-965xxx	170 - 450	1800	701	350 - 900	1800	702	600 - 1800	1400	703

Dimensions

Type	Art.-No.	Bore d		d ₅	D	F ₁	F ₃	G	H ₁	J	K	K ₁	L ₂	Q ₁	R ₁	T	X	Y	Z	Engage-ment travel mm
		min. mm	max. mm																	
SLR 32.x	4470-920xxx	7	20	21	55	38	50	M 5	11,5	3	9	13,5	51,5	8	15	48	38,5	5	6	0,6
SLR 40.x	4470-925xxx	10	25	26	82	50	72,5	M 5	16	6	9	14,5	70	10	20	70	54	6	6	0,8
SLR 55.x	4470-935xxx	14	35	36	100	60	90,5	M 6	15	6	9	15	78	12	25	89	70	6	6	1,1
SLR 65.x	4470-945xxx	18	45	46	120	80	112	M 8	18	8,5	10	22,5	96	12	30	105	84	6	6	1,2
SLR 80.x	4470-955xxx	24	55	56	146	100	140	M 10	23,5	11	9	25	124,5	16	30	125	108	7	6	1,2
SLR 90.x	4470-965xxx	30	70 ¹⁾	66	176	120	170	M 12	25,5	12	9	30	140	18	30	155	129	10	6	1,6

Keyway as per DIN 6885, page 1 · Tolerance of keyway width JS9

¹⁾ Keyway as per DIN 6885, page 3 · Tolerance of keyway width JS9

Example for Ordering

Type	Art.-No.	Preset limit torque	Bore d	with proximity switch
SLR 32. 1	4470-920 701	9 Nm	18 mm	See pages 62 and 63

└─┬─┘
Torque type

└─┬─┘
End number

with single rollers
with long hub

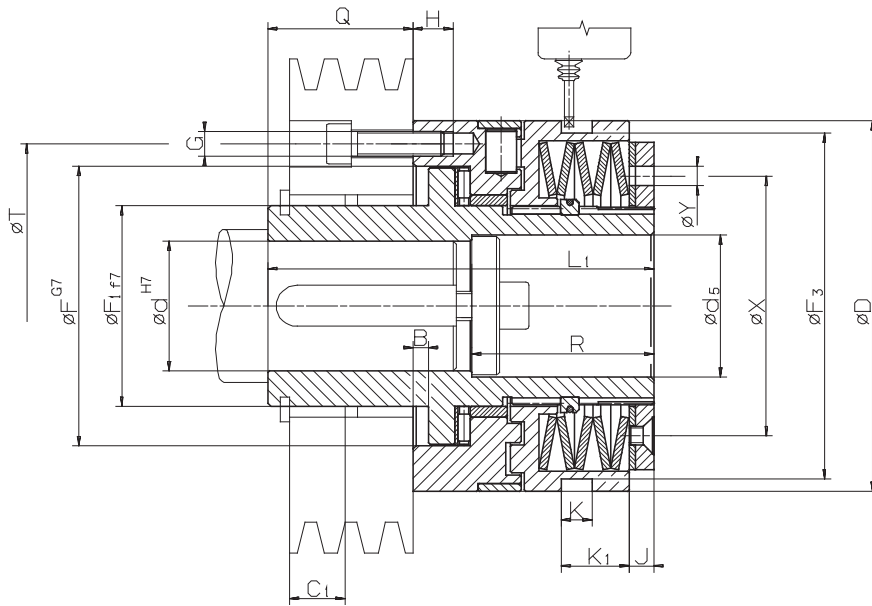

Z = number of tapped holes G on pitch circle T

60-1

Technical Data

Type	Art.-No.	Torque type 1			Torque type 2			Torque type 3		
		Limit torque Nm	max. speed min ⁻¹	End number	Limit torque Nm	max. speed min ⁻¹	End number	Limit torque Nm	max. speed min ⁻¹	End number
SLG 32.x	4470-120xxx	5 - 10	4000	701	10 - 20	4000	702	20 - 40	3000	703
SLG 40.x	4470-125xxx	12 - 25	3900	701	25 - 50	3900	702	50 - 100	2900	703
SLG 55.x	4470-135xxx	25 - 50	3300	701	50 - 100	3300	702	100 - 200	2400	703
SLG 65.x	4470-145xxx	50 - 100	2800	701	100 - 200	2800	702	200 - 450	2000	703
SLG 80.x	4470-155xxx	100 - 200	2300	701	200 - 400	2300	702	400 - 800	1600	703
SLG 90.x	4470-165xxx	170 - 450	1800	701	350 - 900	1800	702	600 - 1800	1400	703

Dimensions

Type	Art.-No.	Bore d		d ₅	B	D	F	F ₁	F ₃	G	H	J	K	K ₁	L ₁	Q	R	T	X	Y	Z	Engage-ment travel mm
		min. mm	max. mm																			
SLG 32.x	4470-120xxx	7	20	21	4	55	41	28	50	M 5	6,5	3	9	13,5	66	27,5	25,5	48	38,5	5	6	0,6
SLG 40.x	4470-125xxx	10	25	26	4	82	60	38	72,5	M 5	8	6	9	14,5	83	33	35	70	54	6	6	0,8
SLG 55.x	4470-135xxx	14	35	36	5	100	78	52	90,5	M 6	10	6	9	15	100	39	45	89	70	6	6	1,1
SLG 65.x	4470-145xxx	18	45	46	5	120	90,5	65	112	M 8	12	8,5	10	22,5	125	47	59	105	84	6	6	1,2
SLG 80.x	4470-155xxx	24	55	56	6,5	146	105	78	140	M 10	15	11	9	25	152,5	52,5	60	125	108	7	6	1,2
SLG 90.x	4470-165xxx	30	70 ¹⁾	66	6,5	176	120,5	90	170	M 12	17	12	9	30	171	57,5	60	155	129	10	6	1,6

Keyway as per DIN 6885, page 1 · Tolerance of keyway width JS9

¹⁾ Keyway as per DIN 6885, page 3 · Tolerance of keyway width JS9

Example for Ordering

Type	Art.-No.	Preset limit torque	Bore d	with proximity switch
SLG 32. 1	4470-120 701	9 Nm	14 mm	See pages 62 and 63

Torque type

End number

with single rollers
with flexible shaft coupling

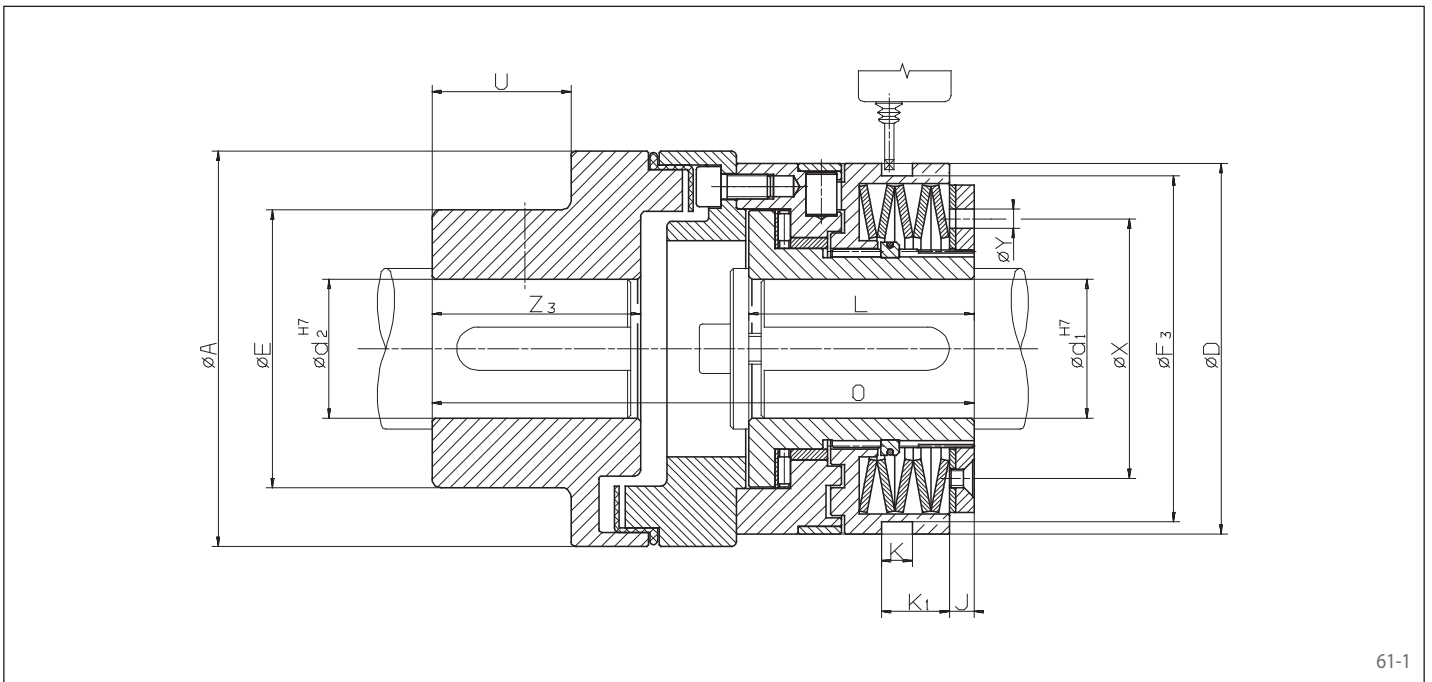

61-1

Technical Data

Type	Art.-No.	Torque type 1			Torque type 2			Torque type 3		
		Limit torque Nm	max. speed min ⁻¹	End number	Limit torque Nm	max. speed min ⁻¹	End number	Limit torque Nm	max. speed min ⁻¹	End number
SLE 32.x	4470-620xxx	5 - 10	4000	701	10 - 20	4000	702	20 - 40	3000	703
SLE 40.x	4470-625xxx	12 - 25	3900	701	25 - 50	3900	702	50 - 100	2900	703
SLE 55.x	4470-635xxx	25 - 50	3300	701	50 - 100	3300	702	100 - 200	2400	703
SLE 65.x	4470-645xxx	50 - 100	2800	701	100 - 200	2800	702	200 - 450	2000	703
SLE 80.x	4470-655xxx	100 - 200	2300	701	200 - 400	2300	702	400 - 800	1600	703
SLE 90.x	4470-665xxx	170 - 450	1800	701	350 - 900	1800	702	600 - 1800	1400	703

Dimensions

Type	Art.-No.	Bore d ₁		d ₂ max. mm	A mm	E mm	D mm	F ₃ mm	J mm	K mm	K ₁ mm	L mm	O mm	U mm	X mm	Y mm	Z ₃ mm	Engage- ment travel mm
		min. mm	max. mm															
SLE 32.x	4470-620xxx	7	20	30	67	46	55	50	3	9	13,5	35	86	15	38,5	5	28	0,6
SLE 40.x	4470-625xxx	10	25	50	112	79	82	72,5	6	9	14,5	48	137,5	38	54	6	58	0,8
SLE 55.x	4470-635xxx	14	35	50	112	79	100	90,5	6	9	15	56	147	38	70	6	58	1,1
SLE 65.x	4470-645xxx	18	45	60	128	90	120	112	8,5	10	22,5	72	176,5	45	84	6	67	1,2
SLE 80.x	4470-655xxx	24	55	60	148	90	146	140	11	9	25	93,5	211,5	45	108	7	67	1,2
SLE 90.x	4470-665xxx	30	70 ¹⁾	70	177	107	176	170	12	9	30	107	242,5	52	129	10	75	1,6
SLE 90.3	4470-665xxx	30	70 ¹⁾	90	198	140	176	170	12	9	30	107	272	52	129	10	75	3,0

Keyway as per DIN 6885, page 1 · Tolerance of keyway width JS9

¹⁾ Keyway as per DIN 6885, page 3 · Tolerance of keyway width JS9

Example for Ordering

Type	Art.-No.	Preset limit torque	Bore d ₁	Bore d ₂	with proximity switch
SLE 32. 1	4470-620 701	8 Nm	11 mm	21 mm	See pages 62 and 63

└─┬─┘
Torque type

└─┬─┘
End number

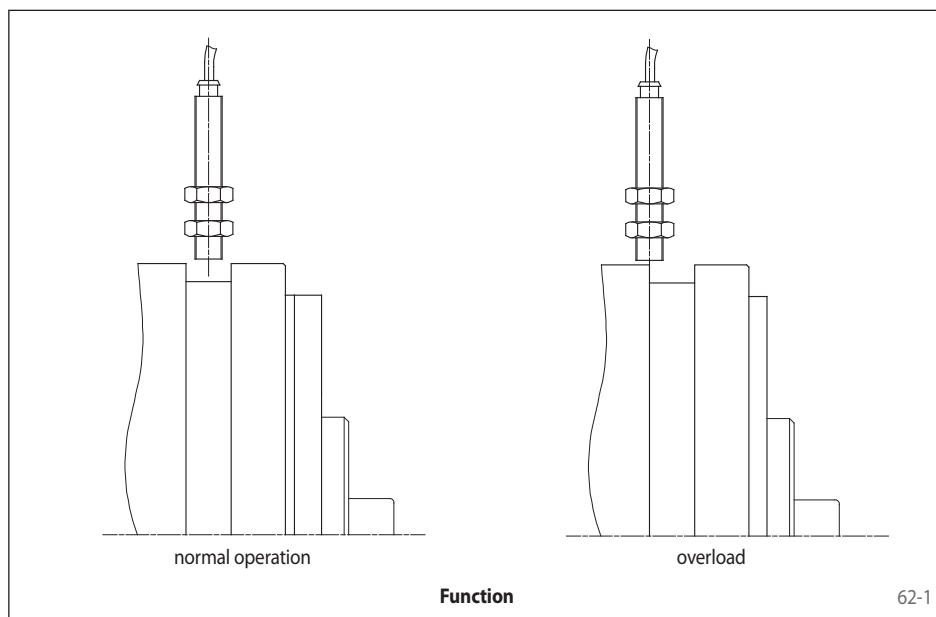

It is possible with SIKUMAT® Torque Limiters to utilise the axial movement during an overload occurrence to actuate a proximity switch so that when the preset limit torque is exceeded, the drive can be switched off electrically and/or a signal can be triggered.

Switching off the drive in case of overload is essential for all ratcheting type SIKUMAT® Torque Limiters in order to prevent ratcheting over prolonged periods and possible wear.

The engagement travel of the SIKUMAT® Torque Limiters can be found in the respective tables.

Non-contact proximity switches operate free from wear and guarantee faster response times than mechanical limit sensors.

DC

Article number:	3505-012001-A00002
Operating voltage:	24 V ±25 %
PNP output	
Max. switching distance:	2 mm
Max. switching current:	200 mA
Switching frequency:	500 Hz
Mounting oscillation:	≤30 %
Output:	= 1 contact
Ambient temperature:	-25° ... +70° C
Connecting cable length:	2 m

AC

Article number:	3504-000073
Operating voltage:	220 V
Electronic contact	
Max. switching distance:	5 mm
Switching frequency:	25 Hz
Ambient temperature:	-25° ... +70° C
Intermittent switching-on load at 220 V:	3 A
Min. required nominal load at 220 V:	5 mA
Permissible nominal load at 200 V:	200 mA
Repeat accuracy:	≤1 %
Connecting cable length:	2 m

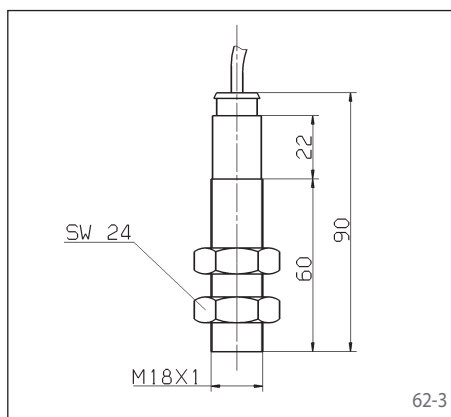
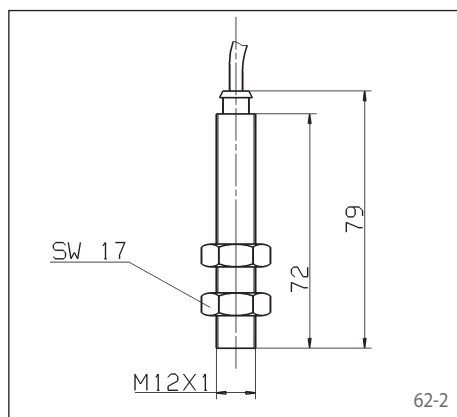

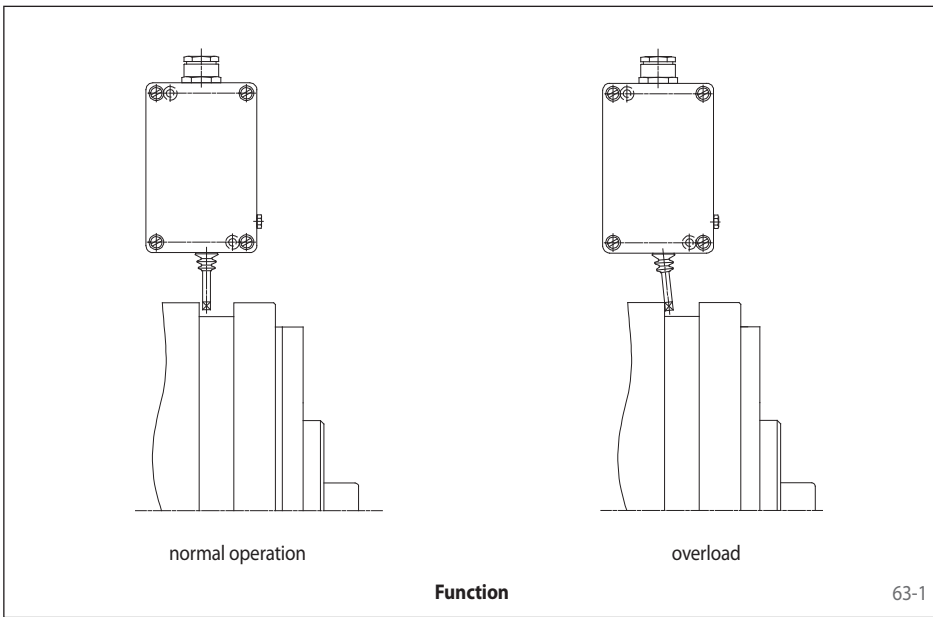

It is possible with SIKUMAT® Torque Limiters to utilise the axial movement during an overload occurrence to actuate a proximity switch so that when the preset limit torque is exceeded, the drive can be switched off electrically and/or a signal can be triggered.

Switching off the drive in case of overload is essential for all ratcheting type SIKUMAT® Torque Limiters in order to prevent ratcheting over prolonged periods and possible wear.

The engagement travel of the SIKUMAT® Torque Limiters can be found in the respective tables.

The arm of the proximity switch should be positioned at a distance of 0,1 mm to the contact surface of the torque limiter.

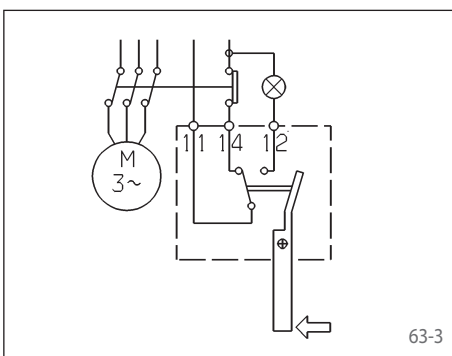
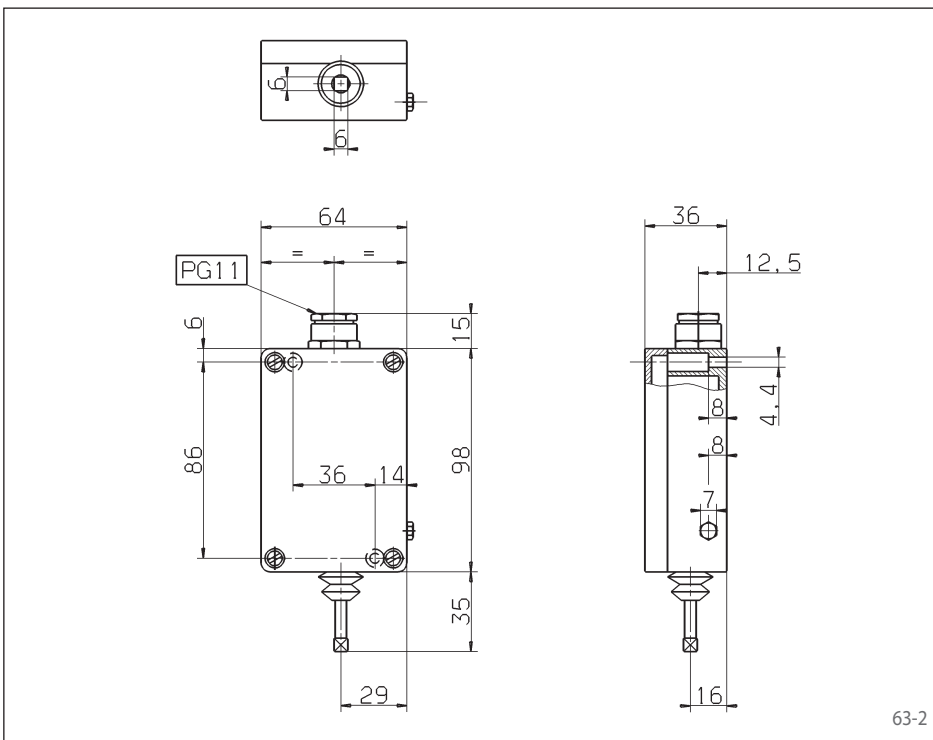

	System voltage V	Rated current A
AC	250	15
	24	6
DC	60	1,5
	250	0,2

Article number: 3502-010001-B240VW

Protection type: IP 54

Ambient temperature: -25° ... +70° C

Max. switching frequency: 3 Hz

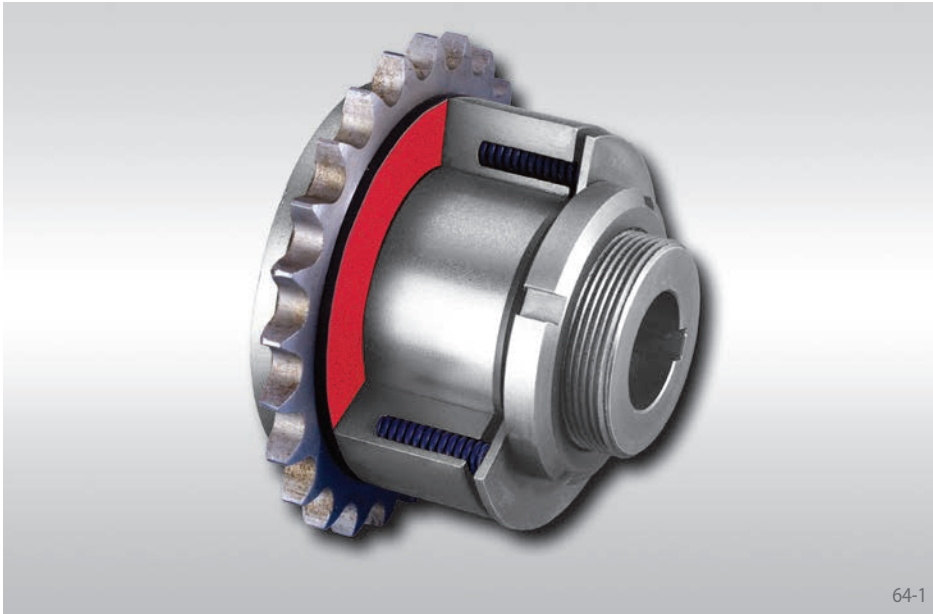

64-1

Advantages

- Particularly suitable in applications with frequent slipping
- Better stability of slipping torque than Belleville spring torque limiters over duration of the operating period
- Adjustment of slipping torque setting according to the number of active springs – not through modification of spring pressure

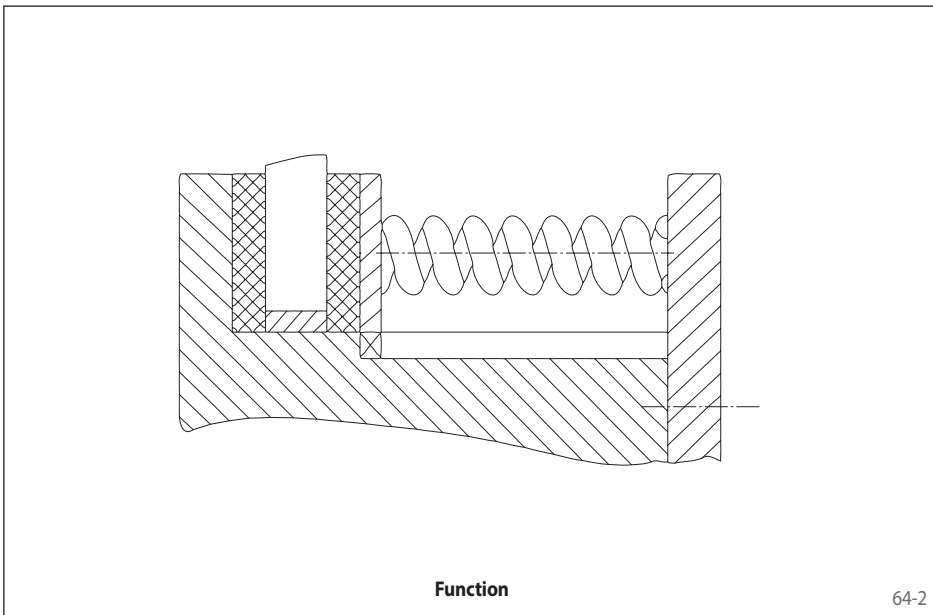

Function

64-2

The RIMOSTAT® Principle

The contact pressure on the friction surfaces is produced by long coil springs. Because of the RIMOSTAT® Torque Limiter's linear, flat-angle characteristic of the pressure force, practically no reduction of the slipping torque occurs even when friction linings are subjected to wear. As the diagram 64-3 shows, compared with Belleville spring torque limiters, assuming a friction wear of Δf the reduction of the slipping torque ΔM is negligible.

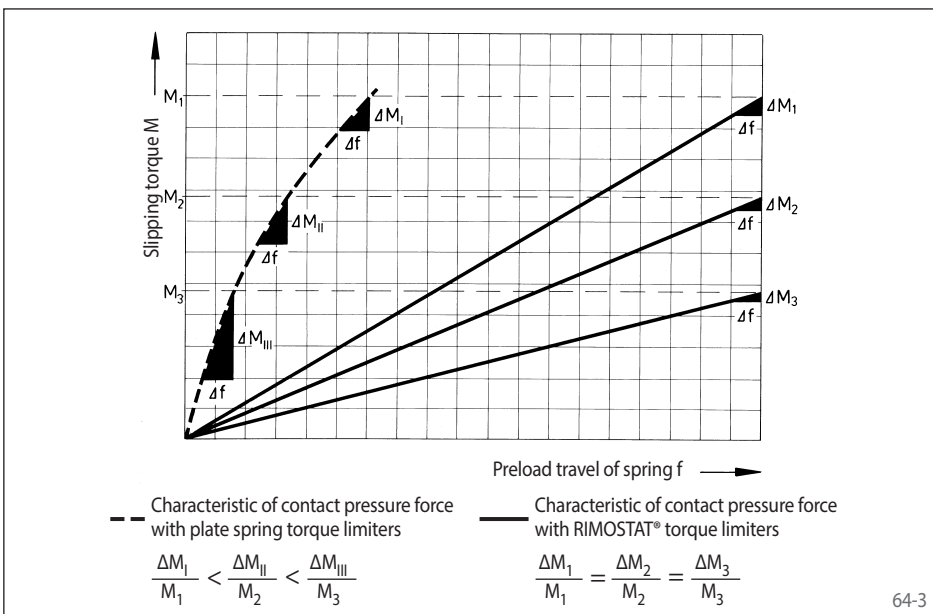

64-3

Function

- When the preset slipping torque has been reached the built-in component (e. g. chain wheel) slips.
- During the slipping process, input and output rotate relative to each other and the preset slipping torque continues to be transmitted.
- Inherent in the slipping process is a high energy consumption.
- Re-engagement is not necessary.

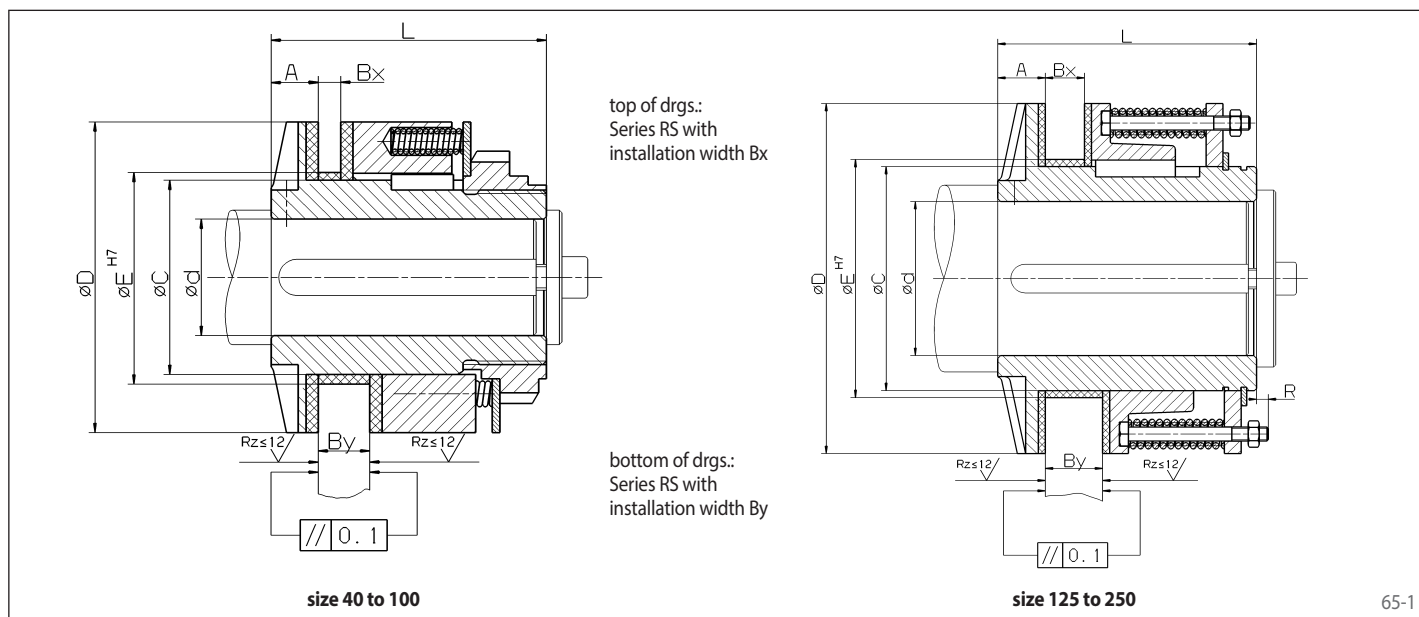

Technical Data and Dimensions

Type	Art.-No.	Slipping torque Nm	Max. speed ¹⁾ min ⁻¹	Bore d^{H7}		A mm	B_x mm	B_y mm	$C^{2)}$ mm	D mm	$E^{2)}$ mm	L mm	R mm
				min. mm	max. mm								
RS 40.1	4474-040820	2 - 12	13000	8	16	8	4,4	7,0	25	40	28	35,5	-
RS 40.2	4474-040920	4 - 25	13000	8	16	8	4,4	7,0	25	40	28	35,5	-
RS 50.1	4474-050820	4 - 25	10500	9	20	8	5,2	8,7	32	50	36	45	-
RS 50.2	4474-050920	8 - 50	10500	9	20	8	5,2	8,7	32	50	36	45	-
RS 63.1	4474-063820	8 - 50	8500	9	25	10	5,8	10,5	40	63	44	56	-
RS 63.2	4474-063920	16 - 100	8500	9	25	10	5,8	10,5	40	63	44	56	-
RS 80.1	4474-080820	10 - 100	6700	15	32	12	5,8	15,3	50	80	55	71	-
RS 80.2	4474-080920	20 - 200	6700	15	32	12	5,8	15,3	50	80	55	71	-
RS 100.1	4474-081820	20 - 200	5350	25	40	15	8,7	18,0	65	100	70	90	-
RS 100.2	4474-081920	40 - 375	5350	25	40	15	8,7	18,0	65	100	70	90	-
RS 125.1	4474-082820	40 - 375	4300	22	55	17	15,3	23,0	80	125	85	105	2,5
RS 125.2	4474-082920	75 - 750	4300	22	55	17	15,3	23,0	80	125	85	105	2,5
RS 160.1	4474-083820	75 - 750	3350	40	70	22	15,3	28,0	100	160	105	130	5,5
RS 160.2	4474-083920	150 - 1500	3350	40	70	22	15,3	28,0	100	160	105	130	5,5
RS 200.1	4474-084820	150 - 1500	2700	50	90	27	23	34,0	125	200	130	160	7,5
RS 200.2	4474-084920	300 - 3000	2700	50	90	27	23	34,0	125	200	130	160	7,5
RS 250.1	4474-085820	300 - 3000	2100	55	115	34	28	41,0	160	250	165	185	9,0
RS 250.2	4474-085920	600 - 6000	2100	55	115	34	28	41,0	160	250	165	185	9,0

¹⁾ The max. speed relates to the design straight of the Torque Limiter; the max. permissible speed differential Δn should be checked according to the heat calculation on page 73.

²⁾ If the part to be coupled is used without bearing bush, the bore should be made to dimension C (tolerance F8).

Keyway as per DIN 6885, page 1 · Tolerance of keyway width P9. Further sizes available on request.

Width of parts to be connected

Components may be connected with either width B_x or B_y .

Supply

Unless requested otherwise, the Torque Limiters are supplied pilot bored, a full complement of springs, without slipping torque setting and without bearing bush. Factory slipping torque setting is only possible when the order includes built-in component (RSK and RSC) and finish bore.

Accessories

- Width B_x or B_y bearing bushes
- Standard tools are normally sufficient for adjusting the slipping torque. Only sizes 125 and 160 require a tool adapter which can be ordered from us.

Please specify when ordering

- Type of Torque Limiter
- Diameter d , if finish bore is requested
- Width of bearing bush B_x or B_y

with chain wheel

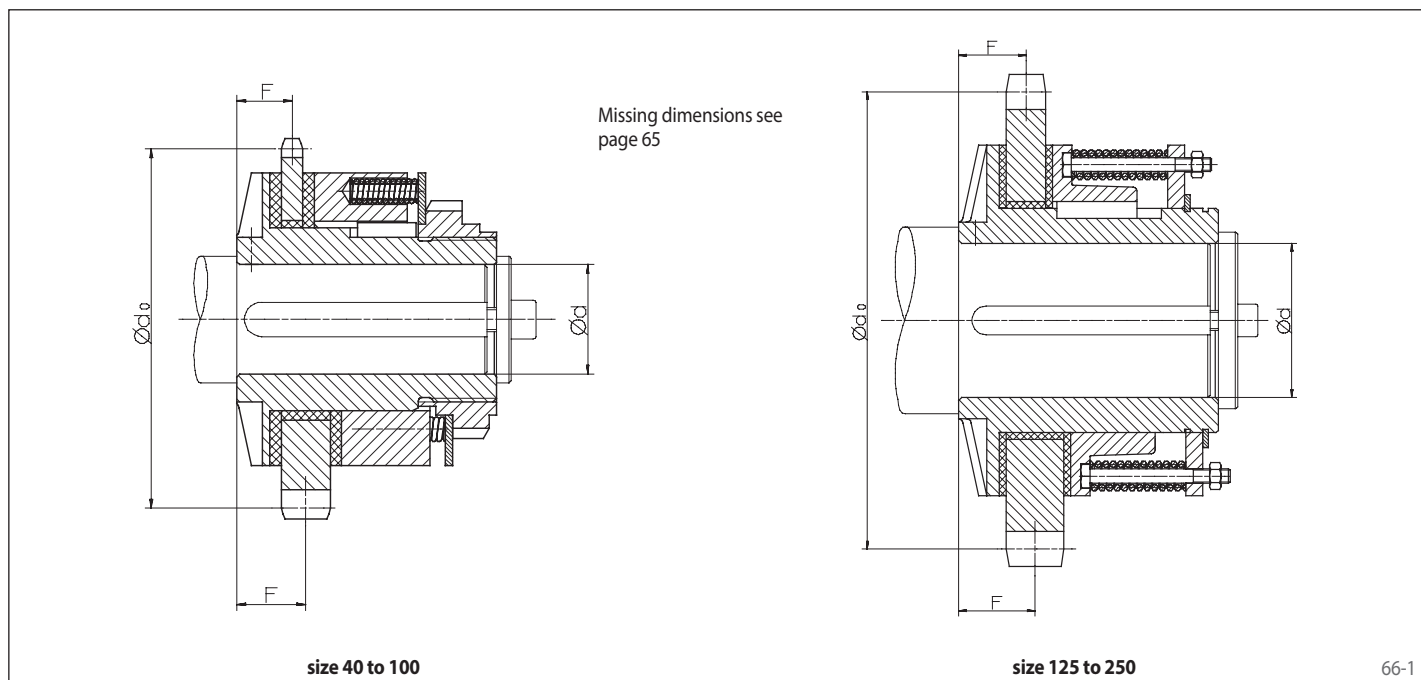

Technical Data and Dimensions

Type	Art.-No.	Slipping torque Nm	Bore d ^{h7}		Chainwheel suitable for simple roller chain as per DIN 8154 or DIN 8187						F mm
			min. mm	max. mm	Roller chain dimensions			N° of teeth Z mm	Pitch circle-ø d ₀ mm	Chainwheel- width B mm	
					Pitch mm	Inner width mm	Roller-ø mm				
RSK 40.1	4474-040822	2 - 12	8	16	9,525	x 4,77	x 5,08	17	51,8	4,4	10,2
RSK 40.2	4474-040922	4 - 25	8	16	9,525	x 4,77	x 5,08	17	51,8	4,4	10,2
RSK 40.1	4474-040823	2 - 12	8	16	12,70	x 7,75	x 8,51	14	57,1	7,0	11,5
RSK 40.2	4474-040923	4 - 25	8	16	12,70	x 7,75	x 8,51	14	57,1	7,0	11,5
RSK 50.1	4474-050821	4 - 25	9	20	9,525	x 5,72	x 6,35	20	60,9	5,2	10,6
RSK 50.2	4474-050921	8 - 50	9	20	9,525	x 5,72	x 6,35	20	60,9	5,2	10,6
RSK 50.1	4474-050823	4 - 25	9	20	15,87	x 9,65	x 10,16	14	71,3	8,7	12,4
RSK 50.2	4474-050923	8 - 50	9	20	15,87	x 9,65	x 10,16	14	71,3	8,7	12,4
RSK 63.1	4474-063822	8 - 50	9	25	12,70	x 6,40	x 8,51	20	81,2	5,8	12,9
RSK 63.2	4474-063922	16 - 100	9	25	12,70	x 6,40	x 8,51	20	81,2	5,8	12,9
RSK 63.1	4474-063823	8 - 50	9	25	19,05	x 11,68	x 12,07	14	85,6	10,5	15,0
RSK 63.2	4474-063923	16 - 100	9	25	19,05	x 11,68	x 12,07	14	85,6	10,5	15,0
RSK 80.1	4474-080822	10 - 100	15	32	12,70	x 6,40	x 8,51	23	93,3	5,8	15,0
RSK 80.2	4474-080922	20 - 200	15	32	12,70	x 6,40	x 8,51	23	93,3	5,8	15,0
RSK 80.1	4474-080823	10 - 100	15	32	25,40	x 17,02	x 15,88	13	106,1	15,3	19,8
RSK 80.2	4474-080923	20 - 200	15	32	25,40	x 17,02	x 15,88	13	106,1	15,3	19,8
RSK 100.1	4474-081821	20 - 200	25	40	15,87	x 9,65	x 10,16	24	121,6	8,7	19,5
RSK 100.2	4474-081921	40 - 375	25	40	15,87	x 9,65	x 10,16	24	121,6	8,7	19,5
RSK 100.1	4474-081823	20 - 200	25	40	31,75	x 19,56	x 19,05	13	132,7	18,0	24,1
RSK 100.2	4474-081923	40 - 375	25	40	31,75	x 19,56	x 19,05	13	132,7	18,0	24,1
RSK 125.1	4474-082821	40 - 375	22	55	25,40	x 17,02	x 15,88	19	154,3	15,3	24,8
RSK 125.2	4474-082921	75 - 750	22	55	25,40	x 17,02	x 15,88	19	154,3	15,3	24,8
RSK 125.1	4474-082823	40 - 375	22	55	38,10	x 25,40	x 25,40	14	171,2	23,0	28,7
RSK 125.2	4474-082923	75 - 750	22	55	38,10	x 25,40	x 25,40	14	171,2	23,0	28,7
RSK 160.1	4474-083821	75 - 750	40	70	25,40	x 17,02	x 15,88	23	186,5	15,3	29,7
RSK 160.2	4474-083921	150 - 1500	40	70	25,40	x 17,02	x 15,88	23	186,5	15,3	29,7
RSK 160.1	4474-083823	75 - 750	40	70	50,80	x 30,99	x 29,21	13	212,3	28,0	36,0
RSK 160.2	4474-083923	150 - 1500	40	70	50,80	x 30,99	x 29,21	13	212,3	28,0	36,0
RSK 200.1	4474-084821	150 - 1500	50	90	38,10	x 25,40	x 25,40	20	243,6	23,0	38,5
RSK 200.2	4474-084921	300 - 3000	50	90	38,10	x 25,40	x 25,40	20	243,6	23,0	38,5
RSK 200.1	4474-084823	150 - 1500	50	90	63,50	x 38,10	x 39,37	13	265,4	34,0	44,0
RSK 200.2	4474-084923	300 - 3000	50	90	63,50	x 38,10	x 39,37	13	265,4	34,0	44,0
RSK 250.1	4474-085821	300 - 3000	55	115	44,45	x 30,99	x 27,94	21	298,3	28,0	48,0
RSK 250.2	4474-085921	600 - 6000	55	115	44,45	x 30,99	x 27,94	21	298,3	28,0	48,0
RSK 250.1	4474-085823	300 - 3000	55	115	76,20	x 45,72	x 48,26	14	342,4	41,0	54,5
RSK 250.2	4474-085923	600 - 6000	55	115	76,20	x 45,72	x 48,26	14	342,4	41,0	54,5

Keyway as per DIN 6885, page 1 • Tolerance of keyway width P9

The glidebush is incorporated as standard. Further chainwheels available on request. Factory slipping torque setting only possible for orders incl. finished bore. Further notes please refer to page 65.

with flexible chain coupling

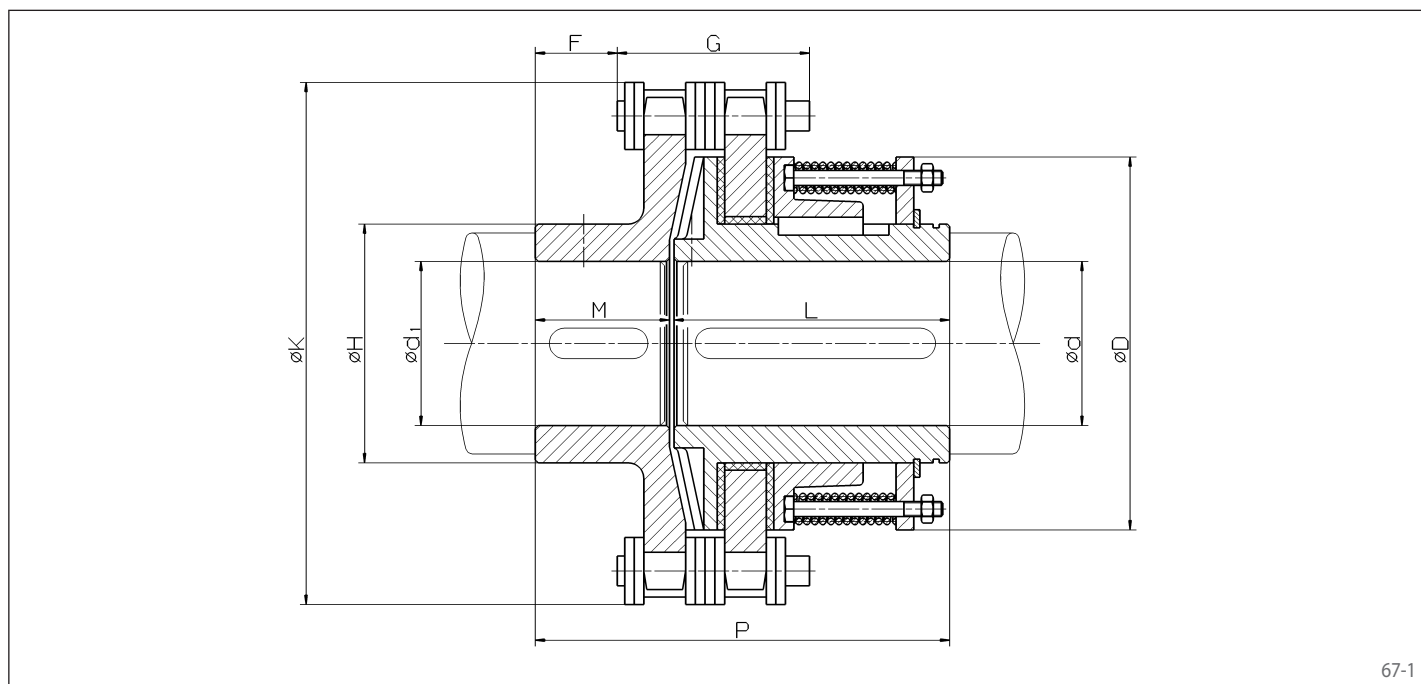

67-1

Technical Data and Dimensions

Type	Art.-No.	Slipping torque Nm	Max. speed min ⁻¹	Bore d ^{H7}		Bore d ₁ ¹⁾		D mm	F mm	G mm	H mm	K mm	L mm	M mm	P mm
				min. mm	max. mm	min. mm	max. mm								
RSC 40.1	4474-240820	2 - 12	6300	8	16	10	24	40	15	23	35	61	35,5	19,0	55,5
RSC 40.2	4474-240920	4 - 25	6300	8	16	10	24	40	15	23	35	61	35,5	19,0	55,5
RSC 50.1	4474-250820	4 - 25	5300	9	20	13	30	50	16	25	45	70	45	21,5	67,5
RSC 50.2	4474-250920	8 - 50	5300	9	20	13	30	50	16	25	45	70	45	21,5	67,5
RSC 63.1	4474-263820	8 - 50	4250	9	25	17	44	63	17	33	60	94	56	25,5	83,0
RSC 63.2	4474-263920	16 - 100	4250	9	25	17	44	63	17	33	60	94	56	25,5	83,0
RSC 80.1	4474-280820	10 - 100	3350	15	32	17	50	80	19	33	70	106	71	24,0	97,0
RSC 80.2	4474-280920	20 - 200	3350	15	32	17	50	80	19	33	70	106	71	24,0	97,0
RSC 100.1	4474-281820	20 - 200	2650	25	40	17	58	100	25	38	80	137	90	30,0	123,0
RSC 100.2	4474-281920	40 - 375	2650	25	40	17	58	100	25	38	80	137	90	30,0	123,0
RSC 125.1	4474-282820	40 - 375	2120	22	55	26	75	125	25	75	100	180	105	46,5	154,5
RSC 125.2	4474-282920	75 - 750	2120	22	55	26	75	125	25	75	100	180	105	46,5	154,5
RSC 160.1	4474-283820	75 - 750	1700	40	70	26	82	160	35	75	110	211	130	51,5	184,5
RSC 160.2	4474-283920	150 - 1500	1700	40	70	26	82	160	35	75	110	211	130	51,5	184,5
RSC 200.1	4474-284820	150 - 1500	1320	50	90	26	105	200	37	113	140	280	160	70,0	233,0
RSC 200.2	4474-284920	300 - 3000	1320	50	90	26	105	200	37	113	140	280	160	70,0	233,0
RSC 250.1	4474-285820	300 - 3000	1120	55	115	26	120	250	55	129	160	336	185	90,0	280,0
RSC 250.2	4474-285920	600 - 6000	1120	55	115	26	120	250	55	129	160	336	185	90,0	280,0

¹⁾ Check the stress of the keyway in the case of smaller finish bores d₁ and high slipping torques.
Keyway as per DIN 6885, page 1 • Tolerance of keyway width P9

Application

As slipping shaft coupling to compensate for minor misalignments.

Supply

Unless specified otherwise, the Torque Limiters are supplied with a pilot bore, a full complement of springs and without slipping torque setting. Factory slipping torque setting is only possible when the order includes built-in component (RSK and RSC) and finish bore.

Accessories

- Standard tools are normally sufficient for adjusting the slipping torque. Only sizes 125 and 160 require a tool adapter which can be ordered from us.

Please specify when ordering

- Type of Torque Limiting chain coupling
- Diameter d and d₁, if finish bore is requested
- Slipping torque to be preset, if required

for heavy-duty applications

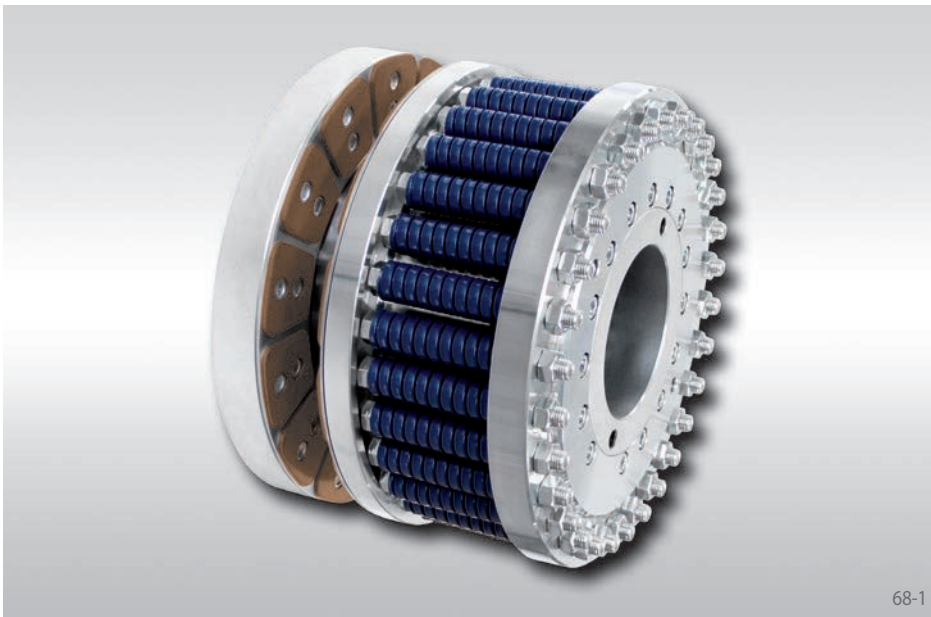

68-1

Features

- Better stability of slipping torque than Belleville spring torque limiters over duration of the operating period
- Adjustment of slipping torque setting according to the number of active springs – not through modification of spring pressure
- Superb wear-behaviour during high energy consumption
- High temperature resistant

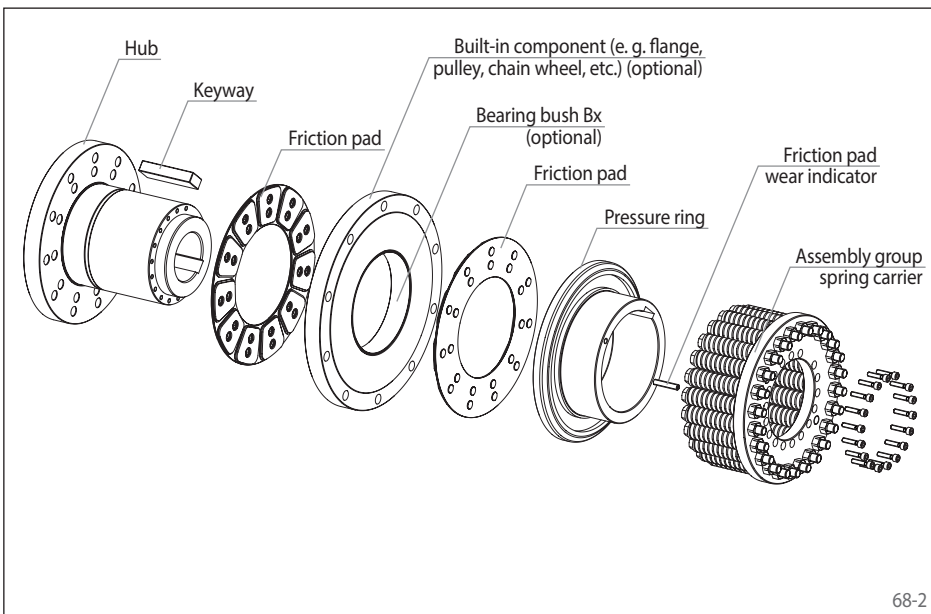

68-2

The RIMOSTAT® Principle

The contact pressure on the friction surfaces is produced by long coil springs. Because of the RIMOSTAT® Torque Limiter's linear, flat-angle characteristic of the pressure force, practically no reduction of the slipping torque occurs even when friction linings are subjected to wear. As the diagram 68-3 shows, compared with Belleville spring torque limiters, assuming a friction wear of Δf the reduction of the slipping torque ΔM is negligible.

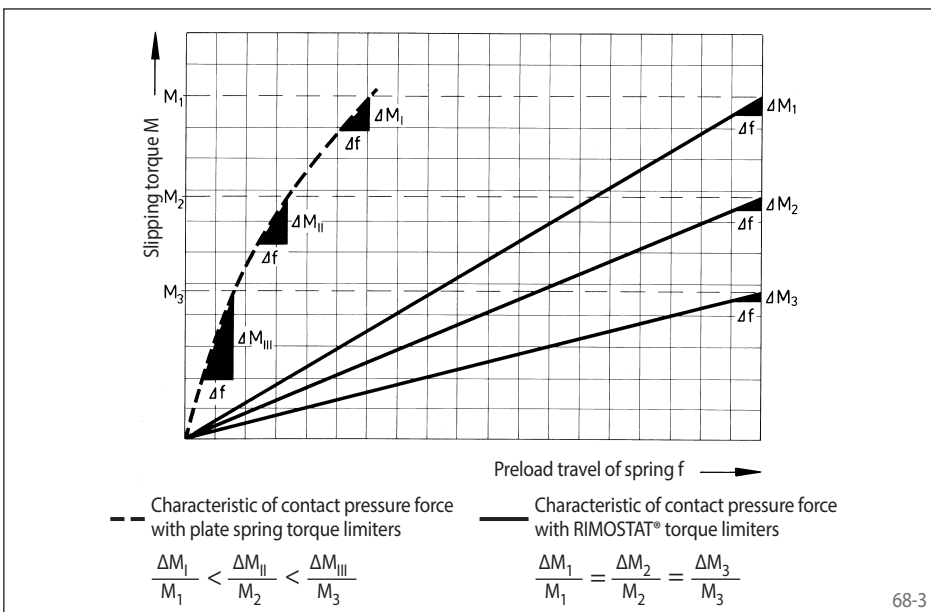

68-3

Function

- When the preset slipping torque has been reached the built-in component (e. g. v-belt pulley) slips.
- During the slipping process, input and output rotate relative to each other and the preset slipping torque continues to be transmitted.
- Inherent in the slipping process is a high energy consumption.
- Re-engagement is not necessary.
- No wear adjustment required due to coil springs.

for heavy-duty applications

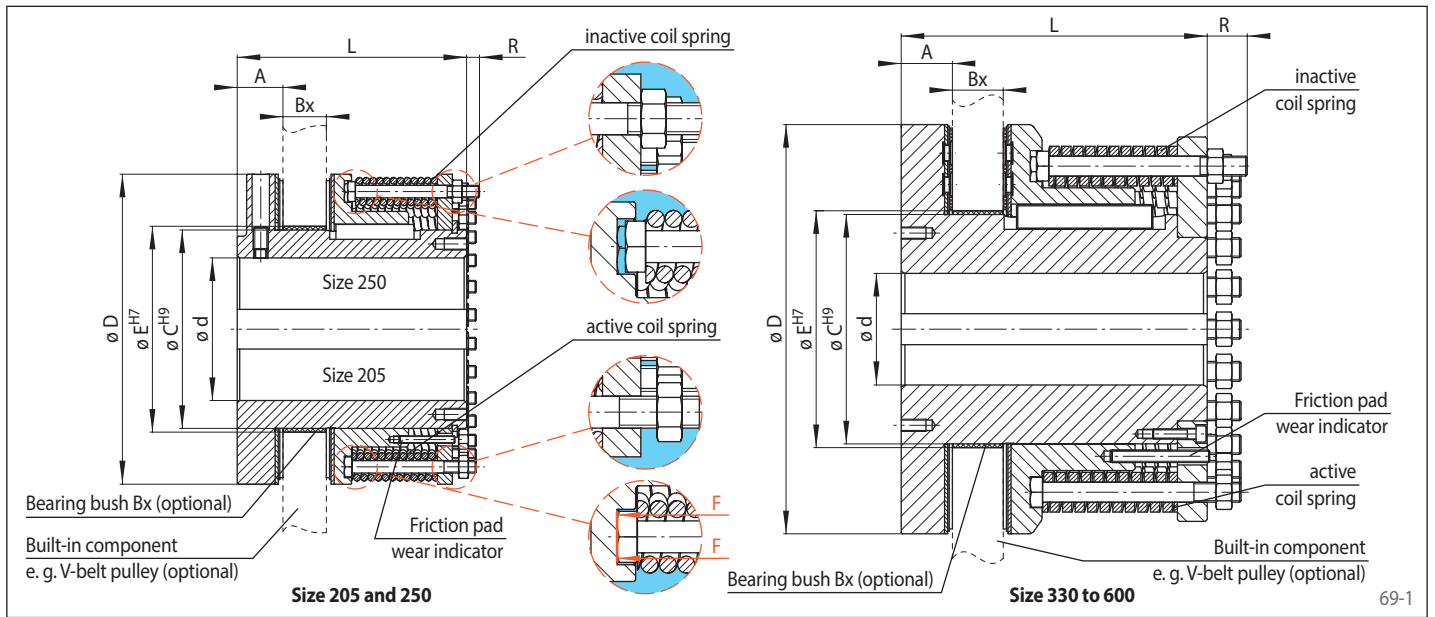

Technical Data and Dimensions

Type	Slipping torque Nm	Max. speed ¹⁾ min ⁻¹	Bore ²⁾ d ^{H7}		A mm	Bx mm	C ³⁾ mm	D mm	E ⁴⁾ mm	L mm	R ⁵⁾ mm	Weight ⁶⁾ kg
			min. mm	max. mm								
RSHD 205	600 - 3 000	2 700	50	90	29,9	28	125	205	131	160	10	26,6
RSHD 250	1 200 - 6 000	2 100	55	115	36,9	35	160	250	166	185	10	46,5
RSHD 330	3 000 - 14 000	1 800	90	125	41,3	41	185	330	191	247	30	103,0
RSHD 400	5 000 - 24 000	1 500	125	150	51,3	63	250	400	260	286	22	173,6
RSHD 500	8 000 - 50 000	1 200	150	200	56,3	63	350	500	360	275	48	292,0
RSHD 600	10 000 - 68 000	1 000	150	300	66,3	63	450	600	460	298	35	510,5

¹⁾The max. speed relates to the dimensional stability of the Torque Limiter. • ²⁾Further bores as well as internal spline available on request. • ³⁾Without a RINGSPANN bearing bush, the bore C must have a tolerance H9 and a surface finish of Rz ≤ 10. • ⁴⁾If the optional RINGSPANN bearing bush is used, the bore in the built-in component must be manufactured to tolerance H7. • ⁵⁾Dimension for inactive springs. • ⁶⁾Weight with smallest bore.

The friction surfaces of the built-in component must have the total axial runout of ≤ 0.05 to the bore and the surface quality of Rz12.

Keyway as per DIN 6885, page 1 · Tolerance of keyway width P9. Further designs available on request.

Supply

The Torque Limiters are supplied with inactive coil springs when fully equipped, without slipping torque setting and without bearing bush. An optical friction pad wear indicator is integrated. A factory slipping torque preset is only possible with a built-in component e. g. V-belt pulley.

Types (optional)

- Special bore designs on request
- Design also for connecting two shaft ends
- Can be combined with Flexible Couplings

Accessories

Torque Limiter RSHD is available with the following accessories:

- Bearing bush Bx
- V-belt pulley
- Split V-belt pulley
- Built-in component as flange design

Please specify when ordering

- Type of Torque Limiter
- Information of the bore
- Bearing bush required: Yes / No
- Information on the built-in component, if applicable
- Specify slipping torque (torque setting only possible with built-in component)



RIMOSTAT®-Torque Limiter RSHD with Pin and Bush Coupling
REB ... DCO

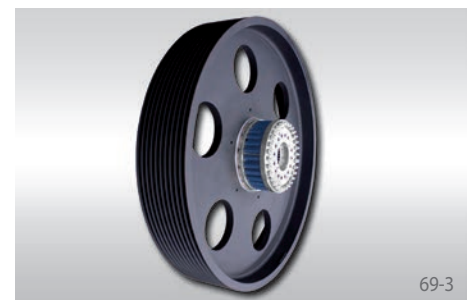

RIMOSTAT®-Torque Limiter RSHD for heavy-duty applications with V-belt pulley



Advantages

- Cost effective, simple Torque Limiter
- Adjustment option for pad wear
- 12 Sizes for slipping torques from 0,5 Nm to 10 000 Nm

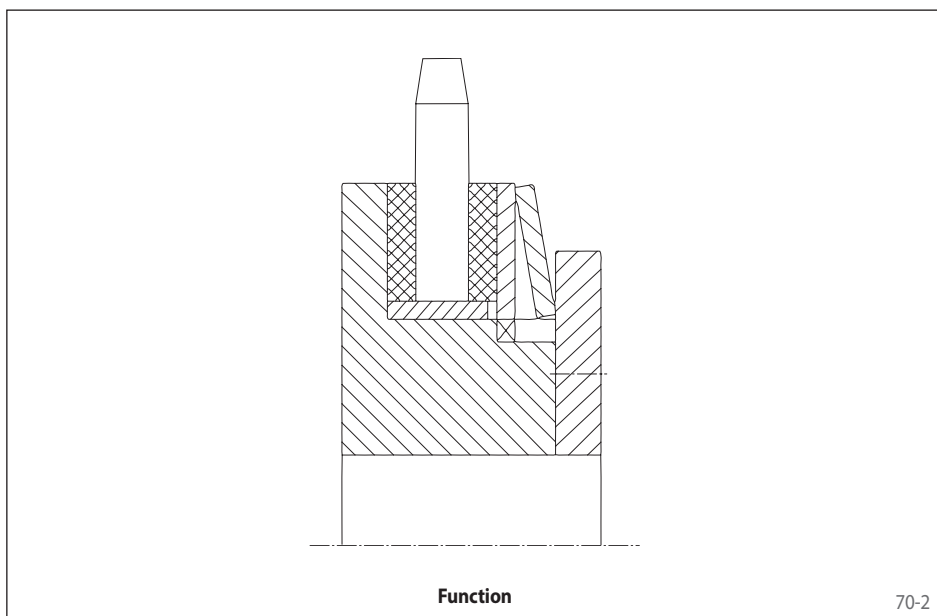

The Belleville Spring Principle

Belleville springs produce the contact force on the friction linings. Because of the Belleville spring torque limiters' steep characteristic of the contact force the spring preload needs to be readjusted when the friction linings become worn. Belleville spring Torque Limiters are therefore preferred in applications where slipping periods are short and infrequent.

Function

- When the preset slipping torque has been reached the built-in component (e. g. chain wheel) slips.
- During the slipping process, input and output rotate relative to each other and the preset slipping torque continues to be transmitted.
- Inherent in the slipping process is a high energy consumption.
- Re-engagement is not necessary.

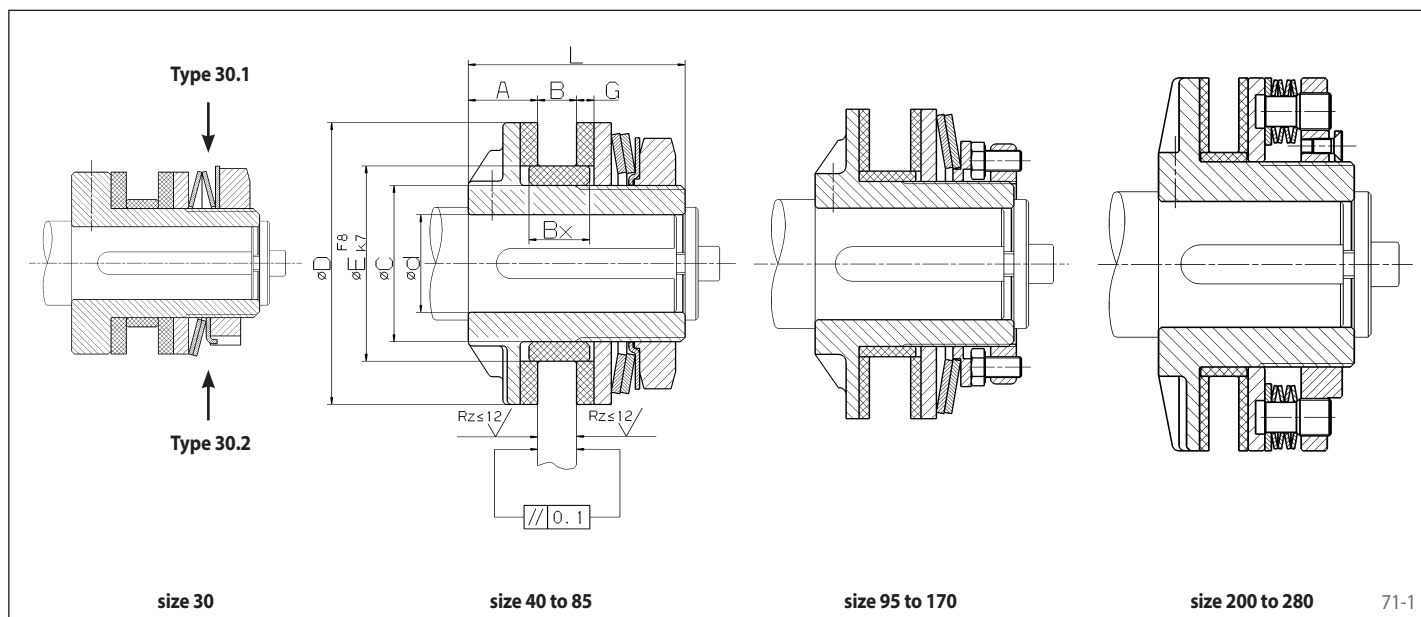

Technical Data and Dimensions

Type	Art.-No.	Slipping torque Nm	Max. speed min ⁻¹	Bore d ^{H7}			A mm	B max. mm	Bx ³⁾ mm	C mm	D mm	E mm	L mm	G mm
				min. ¹⁾ mm	max. ¹⁾ mm	max. ²⁾ mm								
RT 30.1	4476-003001	0,5 - 5	1500	5,5	11	12	9,0	6	6	18	30	21	31	2,5
RT 30.2	4476-003002	1 - 10	1500	5,5	11	12	9,0	6	6	18	30	21	31	2,5
RT 40.1	4476-004001	5 - 15	800	8	14	16	8,0	7	8	22	40	26	28	2,8
RT 40.2	4476-004002	8 - 28	800	8	14	16	8,0	7	8	22	40	26	28	2,8
RT 40.3	4476-004003	12 - 40	800	8	14	16	8,0	7	8	22	40	26	28	2,8
RT 45.1	4476-004501	9 - 30	700	8	20	22	8,5	8	9	32	45	35	33	3,0
RT 45.2	4476-004502	14 - 55	700	8	20	22	8,5	8	9	32	45	35	33	3,0
RT 45.3	4476-004503	15 - 70	700	8	20	22	8,5	8	9	32	45	35	33	3,0
RT 65.1	4476-006501	20 - 70	700	11	22	25	16,0	13	14	36	65	45	50	4,0
RT 65.2	4476-006502	32 - 120	700	11	22	25	16,0	13	14	36	65	45	50	4,0
RT 85.1	4476-008501	16 - 130	600	16	30	30	17,0	15	16	42	85	52	55	4,0
RT 85.2	4476-008502	26 - 240	600	16	30	30	17,0	15	16	42	85	52	55	4,0
RT 95.1	4476-009501	22 - 190	600	16	35	38	18,0	15	16	52	95	60	66	4,0
RT 95.2	4476-009502	32 - 340	600	16	35	38	18,0	15	16	52	95	60	66	4,0
RT 120.1	4476-012001	25 - 350	500	21	45	48	21,0	20	21	64	120	73	77	4,0
RT 120.2	4476-012002	48 - 650	500	21	45	48	21,0	20	21	64	120	73	77	4,0
RT 140.1	4476-014001	110 - 650	400	21	60	60	23,0	20	22	85	140	90	86	4,0
RT 140.2	4476-014002	125 - 1200	400	21	60	60	23,0	20	22	85	140	90	86	4,0
RT 170.1	4476-017001	80 - 1000	350	29	65	70	26,5	20	24	90	170	100	93	4,6
RT 170.2	4476-017002	200 - 1800	350	29	65	70	26,5	20	24	90	170	100	93	4,6
RT 200.1	4476-020001	636 - 2200	250	37	80	80	27,0	20	24	110	200	120	105	5,0
RT 200.2	4476-020002	890 - 4000	250	37	80	80	27,0	20	24	110	200	120	105	5,0
RT 254.1	4476-025401	1145 - 3800	200	50	90	100	33,0	29	32	125	254	140	120	5,0
RT 254.2	4476-025402	2067 - 6800	200	50	90	100	33,0	29	32	125	254	140	120	5,0
RT 280.1	4476-028001	1510 - 5.500	180	50	120	120	33,0	29	32	155	280	170	120	5,0
RT 280.2	4476-028002	2544 - 10.000	180	50	120	120	33,0	29	32	155	280	170	120	5,0

¹⁾ Keyway as per DIN 6885, page 1 · Tolerance of keyway width P9

²⁾ Keyway as per DIN 6885, page 3 · Tolerance of keyway width P9

³⁾ If B+G+1,5 mm > Bx, than use 2 bearings bushes (does not apply to RT 30.X).

Supply

Unless specified otherwise, the Torque Limiters are supplied with a pilot bore, including plain bearing and friction linings.

Accessories

- All sizes available with chain wheel

Please specify when ordering

- Type of Torque Limiter
- Diameter d, if finish bore is requested

Symbols

M_L [Nm]	Torque requirement of machine whilst operating	n [r.p.m.]	Speed when driving half is running at nominal speed	J [kgm ²]	Mass inertia moment of rotating masses to be accelerated, relative to the speed of the torque limiter
M_{La} [Nm]	Average starting torque of machine	n_a [r.p.m.]	Speed when torque limiter is slipping (driven half)	P_R $\left[\frac{\text{Nm}}{\text{s}} = \text{W} \right]$	Standard friction power
M_K [Nm]	Preset friction slip torque of torque limiter	Δn [r.p.m.]	Speed differential between input and output	P_a $\left[\frac{\text{Nm}}{\text{s}} = \text{W} \right]$	Occuring friction power
P_L [kW]	Rate of power input of driving half	t_a [s]	Slipping time	$P_{zul.}$ $\left[\frac{\text{Nm}}{\text{s}} = \text{W} \right]$	Max. permissible friction power

Selection

Below are the basic guidelines to be applied for the selection of RIMOSTAT® Torque Limiters:

- If slipping periods are short and very infrequent, the highest transmissible table torque may be utilised.
- For infrequent but longer slipping periods the heat factor should be checked against diagram 1 (page 73).
- For constant friction or frequent, very short slipping periods the heat factor should be checked against diagram 2 (page 73).

Selection of RIMOSTAT® Torque Limiters is carried out of three stages:

1. Selection according to required torque
2. Evaluation of slipping period and speed differential
3. Checking the heat factor

Selection according to required torque load

The torque to be transmitted by the RIMOSTAT® Torque Limiter is to be taken from the tables, as is the permissible speed.

The preset slip torque M_K must exceed the peak starting torque by at least 25% and must be at least 25% higher than the normal running torque M_L of the installation to be driven.

The required operating torque can be calculated from the power absorption of the machine:

$$M_L = 9\,550 \cdot \frac{P_L}{n} \quad [\text{Nm}] \quad (1)$$

Calculation of slipping period and friction power

Application as starter coupling

$$t_a = \frac{J \cdot n}{9,55 (M_K - M_{La})} \quad [\text{s}] \quad (2)$$

For conversion of the old Technical Standard System apply $J \triangleq 0,25 \cdot GD^2$, entering GD^2 as kpm^2 .

The average starting torque M_{La} of the machine or installation during the starting process depends on the type of machine.

For example, in the case of conveyor installations which are started while under load, the torque requirement during the starting process is, after overcoming the breakaway torque requirement during operation, i.e. $M_{La} = M_L$. In the case of ventilators the torque requirement at the beginning of the starting process can be very low and increases during starting process with n^2 i.e. approximately $M_{La} = 0,5 \cdot M_L$.

The differential speed Δn changes during the starting process from n (at the beginning of the starting process) to 0 (after ending the starting process).

One can therefore apply the following calculation to determine the heat:

$$\Delta n = \frac{n}{2} \quad [\text{r.p.m.}] \quad (3)$$

Application as safety coupling

Slipping time can be limited by safety devices, e.g.:

- Speed monitors which disengage the motor when different speeds between input and output of the torque limiter occur
- Thermal motor monitoring units
- Optical control (manual disengagement)

Assuming the driving side is blocked and the motor continues to run at full speed, the differential speed would amount to

$$\Delta n = n \quad [\text{r.p.m.}] \quad (4)$$

Friction Power

The occurring friction power is calculated as follows:

$$P_a = 0,105 \cdot M_K \cdot \Delta n \quad [\text{W}] \quad (5)$$

Checking the heat factor

Application as starter- or safety coupling

Using the calculated slipping time t_a the standard friction power P_R is taken from diagram 1 and multiplied with size factor K according to the table. The resulting friction power $P_{zul.}$ of the selected torque limiter must be greater than the occurring friction power P_a .

Full utilisation of the maximum permissible friction power $P_{zul.}$ at an ambient temperature of 20° C causes the torque limiter to heat to ca. 220° C.

Size	Size factor (K)
RS 40	0,13
RS 50	0,21
RS 63	0,35
RS 80	0,60
RS 100	1,00
RS 125	1,70
RS 160	2,90
RS 200	5,10
RS 250	7,50

Application as permanent slipping hub

The occurring friction power P_a must be calculated using formula (5). It must be lower than the maximum transmissible friction power $P_{zul.}$ of the given speed of the spring support n_a , as shown in diagram 2.

Diagram 1

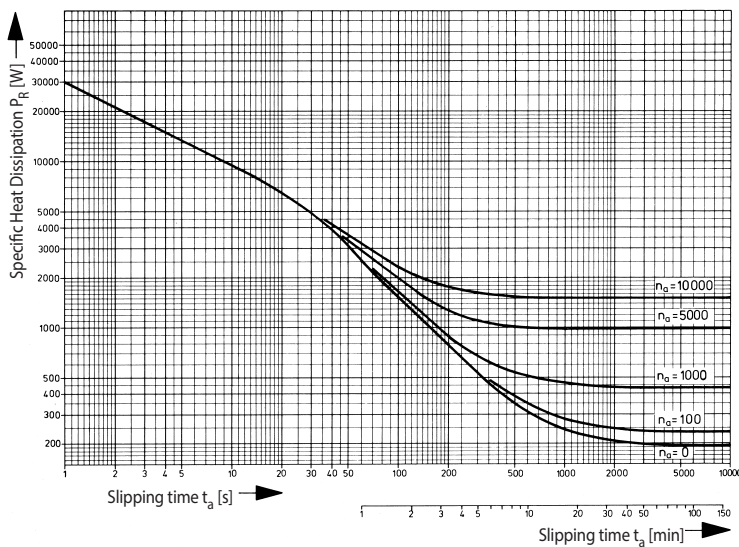
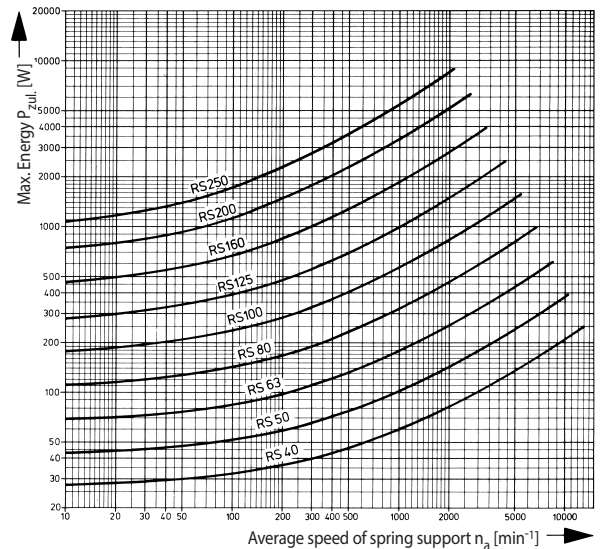
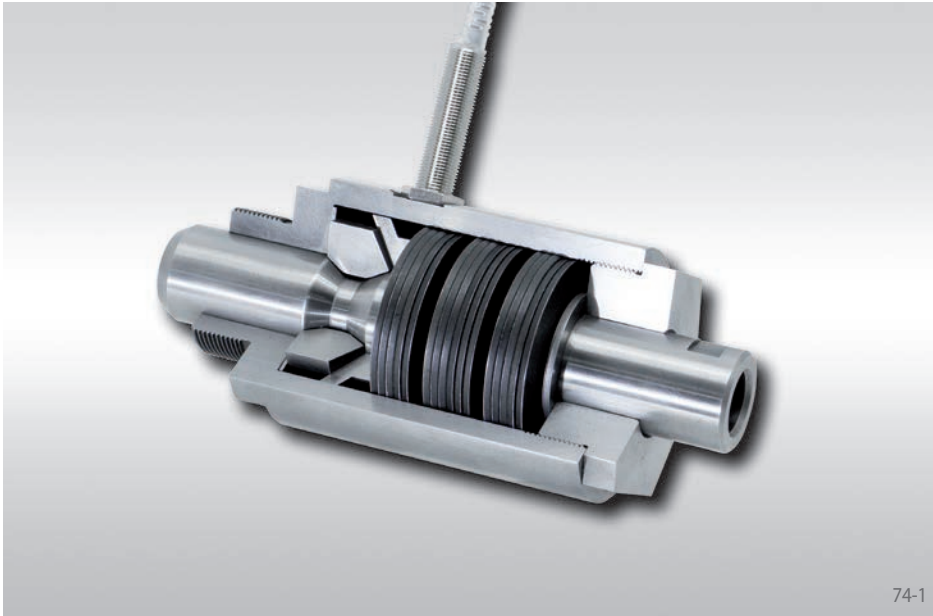

Diagram 2





74-1

Features

- Forces limited in both directions
- High response accuracy
- Automatic re-engagement
- Maintenance-free
- Robust construction
- Uncomplex design
- Easy to build on
- For disengaging forces up to 140 000 N
- Disengaging force finely adjustable

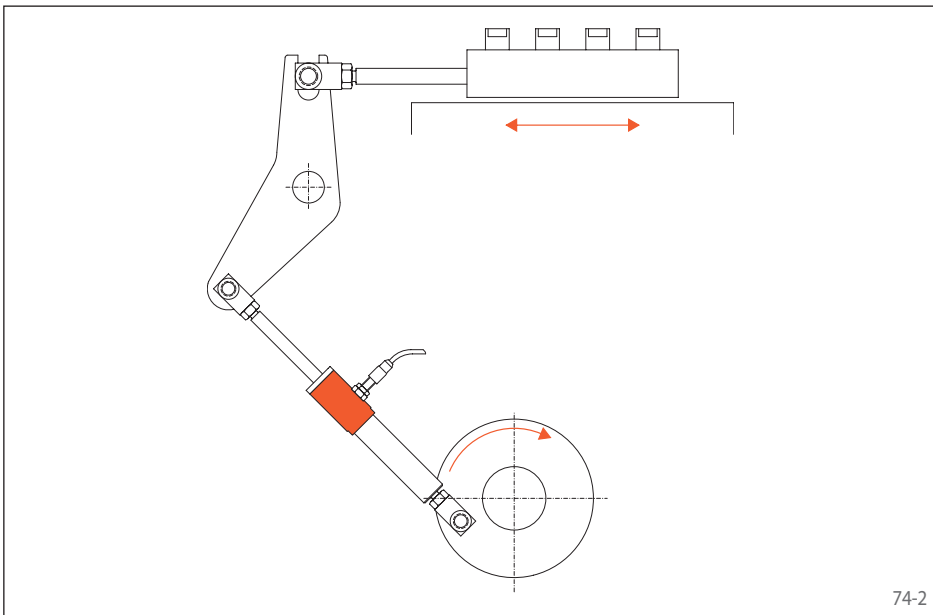

74-2

Application Example

Shown in figure 74-2 is the operation of the feeding equipment for workpieces on an inter-linked installation. The feeding equipment is driven by a crankshaft pin on the output shaft via a connecting rod and a lever. The Force Limiter with non-contact proximity switch is built into the connecting rod as shown in figure 74-2.

If the material jams the force in the connecting rod increases considerably, causing extensive damage in the machine if there is no safety installation available. The Force Limiter ensures that no excessive high forces reach the feed mechanism. If the force in the Force Limiter exceeds its preset limit it disengages and, through the non-contact proximity switch, a signal is given to switch off the drive.

Why RINGSPANN Force Limiters?

There are many ways of transmitting forces and torques in machines, installations and vehicles. The advances in constructional engineering are marked by components which run faster and are of a lighter construction. Therefore it has become necessary to provide for safety elements at the critical points. Until now these were usually in the shape of overload clutches on rotating shafts which, once the maximum torque was exceeded, would either slip, stop, or automatically cut out.

However, many machines and installations have elements which transmit longitudinal forces. To prevent damage and breakdowns a solution for limiting the amount of these forces has to be found. RINGSPANN has designed a series of Force Limiters, outstanding in that forces up to a certain size can be transmitted in both directions completely free of play and rigid. On exceeding the pre-set disengaging force F_A the power of the force is interrupted and the output part is no longer driven. After

the overload has been cleared the driving part and the driven part are aligned towards each other and the Force Limiter re-engages automatically.

The Force Limiter can be fitted with non-contact proximity switch to give early warning of reaching a certain force, or disengaging signal.



RINGSPANN Force Limiter PAG as overload clutch in a filling plant

75-1

Assembly and Operation

Assembly and operation of the RINGSPANN Force Limiter can be seen in illustrations 76-1 and 76-4. The sectional drawing in figure 76-1 shows the standard type of basic unit. The rod (1) is connected with the housing (3) via locking segments (2). The locking segments (2) are pressed into the groove (5) of the rod and against the conical surface (6) of the slide ring via the disc spring pack (4). If a force is effective between the rod and the housing, then, according to figure 76-4, up to force F_B no movement takes place between the two parts. If the force is increased the rod moves relative to the housing until the disengaging force F_A is reached. The force then drops to the value F_C . The loss of force down to F_C is effected according to the direction C. The maximum possible operating force should always be less than F_B and considerably more than F_C . With the RINGSPANN Force Limiter F_B is always larger than $0,7 \times F_A$ and F_C is approx. $0,2 \times F_A$.

This disengaging force F_A can easily be adjusted by changing the number of washers (7). The nut (8) is always tightened against the housing to prevent unauthorised increase of the disengaging force.

Figure 76-2 and 76-3 show the Force Limiter in the disengaged position with the force effective towards the right and left respectively. In both cases one can see clearly that in this position the locking segments are clear of the groove in the rod, the springs are at maximum pressure.

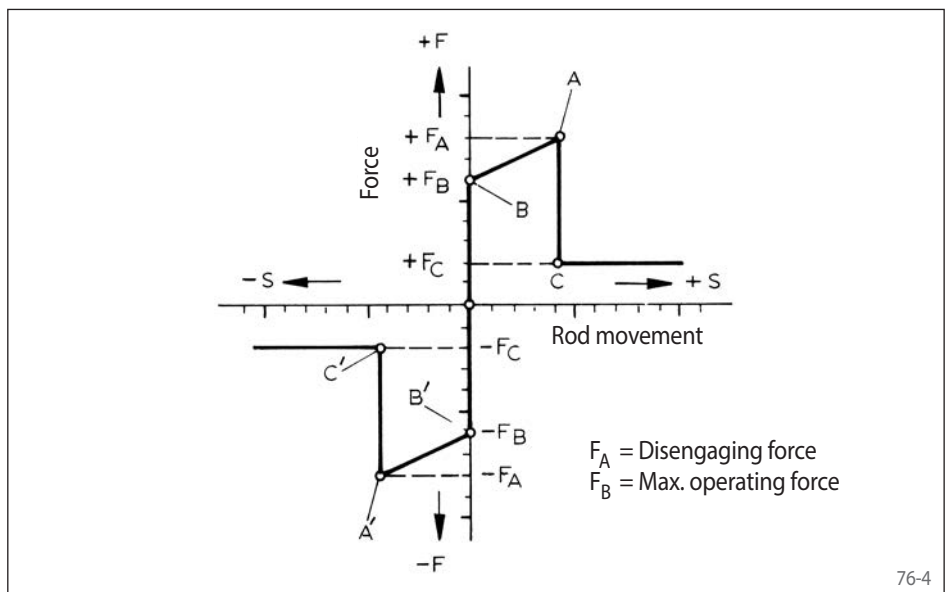
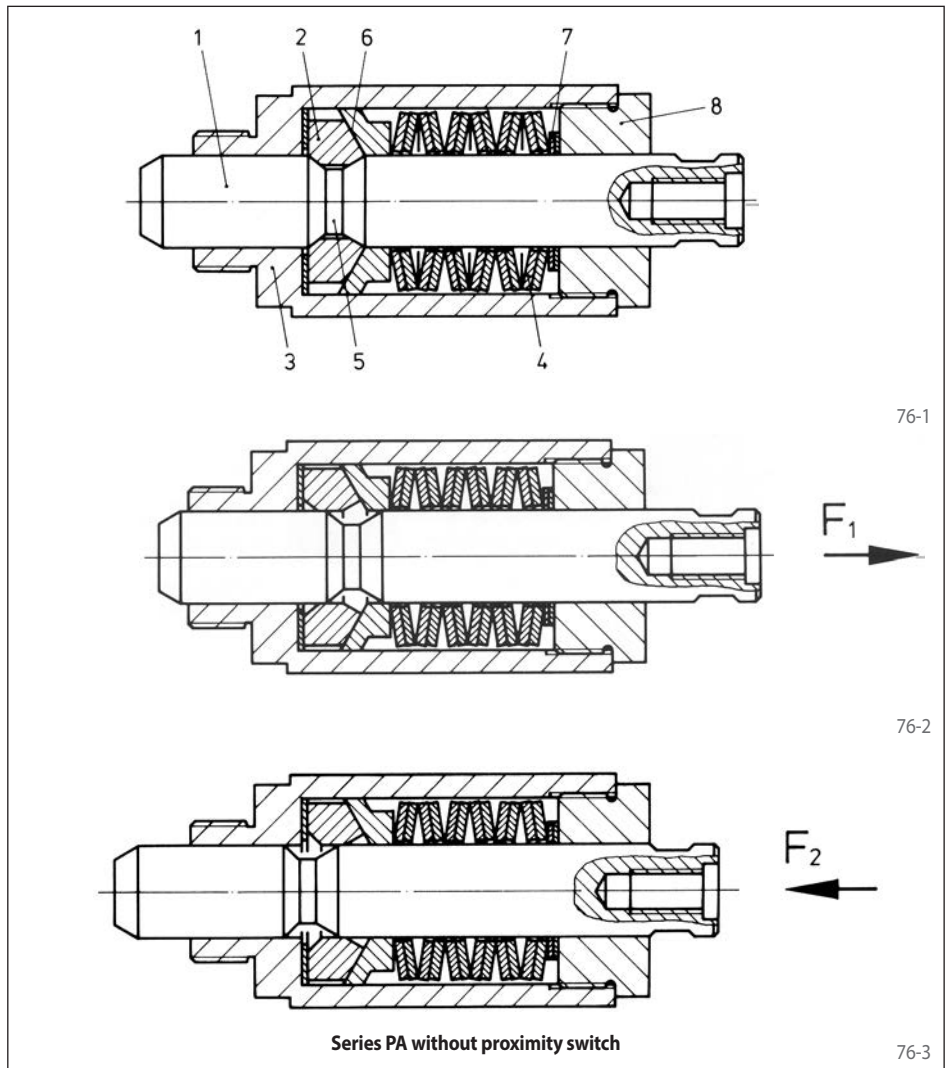

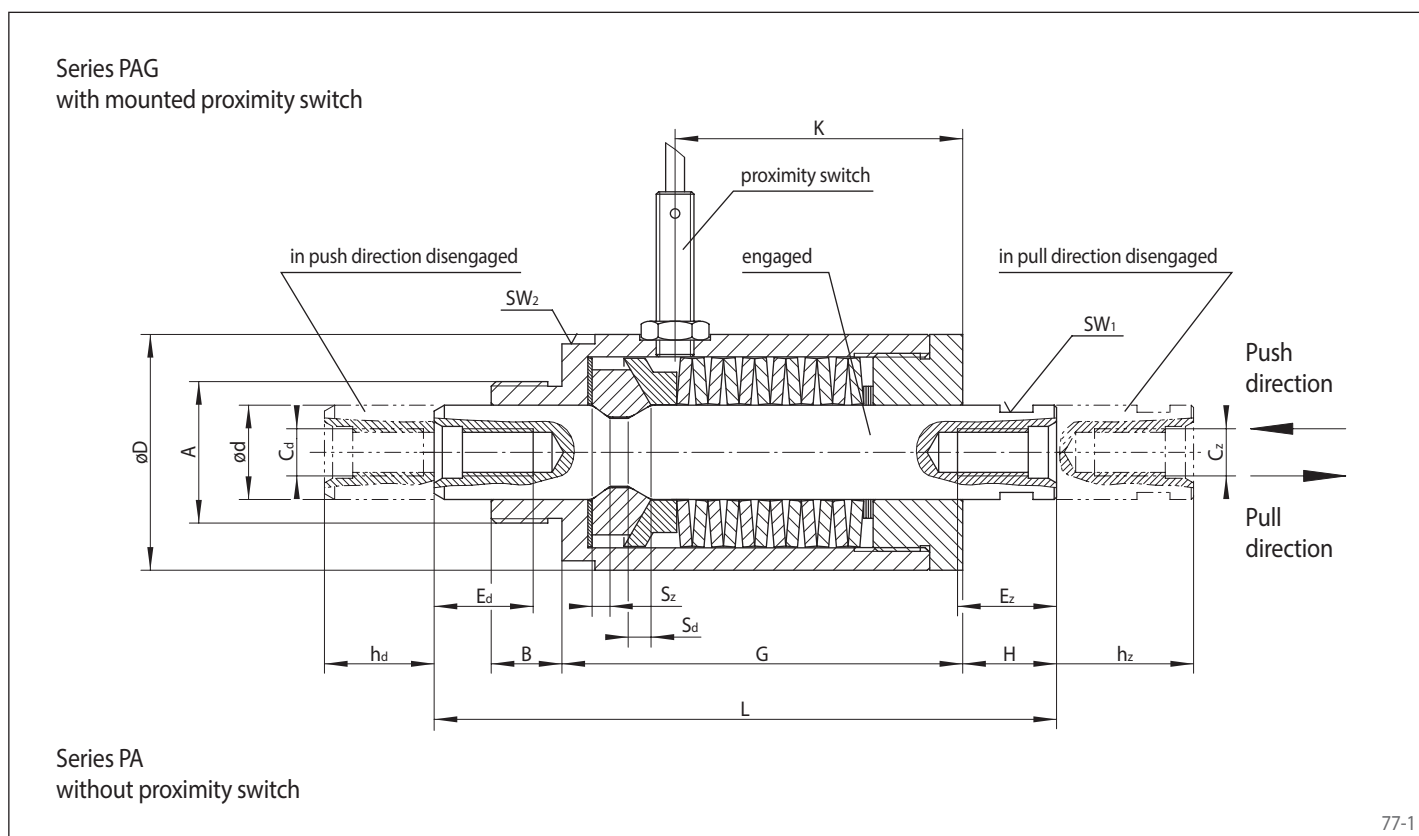

Technical Data and Dimensions

Type		Max. Disengaging Force F_A N	d mm	A	B	C_d	C_z	D	E_d	E_z	G	H	Stroke		K	L	Engagement travel		Across flats	
without proximity switch	with proximity switch												Pressure h_d mm	Tension h_z mm			Pressure S_d mm	Tension S_z mm	SW ₁	SW ₂
PA 12	PAG 12	3600	12	M 20 x 1,5	10	-	M 6	32	-	10	61	16	16	20	38	95	3,5	2,7	11	30
PA 20	PAG 20	10000	20	M 30 x 1,5	15	M 10	M 10	50	16	16	85	20	20	25	57	132	4,3	3,4	17	46
PA 30	PAG 30	22000	30	M 45 x 1,5	20	M 16	M 16	75	25	25	120	24	24	40	78	180	6,9	5,4	27	65
PA 50	PAG 50	62000	50	M 70 x 2,0	28	M 24	M 24	132	40	40	212	36	36	63	150	300	11,3	8,8	46	-
PA 75	PAG 75	140000	75	M 100 x 2,0	40	M 36	M 36	200	60	60	315	57	57	100	215	450	17,3	13,6	70	-

Accessories

- Proximity switch: signals excessive disengaging force for drive unit braking

Proximity switch

Operating voltage:	10-30 V DC
Output:	PNP transistor
Normal condition:	closed
Max. switching current:	200 mA
Domestic electricity requirement:	10 mA
Protection class:	IP 67
Ambient temperature:	-25° ... +75° C
Cable length:	2 m

Ordering

Please indicate the required disengaging force on your order. The Force Limiter can be supplied with preset disengaging force on request.

Other rod lengths and -connections available as special types.

We shall be pleased to advise you on the correct choice and dimension of a suitable Force Limiter.

Questionnaire for the selection of RINGSPANN Torque Limiters

Please photocopy or use the PDF-File from our website!

Company: Address: Phone: Fax:	Department: Name: Enquiry Ref.: Date: E-mail:
1. Type of machine, machine group or plant into which torque limiter is to be installed	
2. Effect Torque limiting through: <input type="checkbox"/> Ratcheting <input type="checkbox"/> Disengaging <input type="checkbox"/> Signals overload without interrupting torque transmission <input type="checkbox"/> Slipping Re-engagement: <input type="checkbox"/> Automatic <input type="checkbox"/> Manual <input type="checkbox"/> Automatic-synchronous after 360° <input type="checkbox"/> Manual-synchronous after 360°	
3. Backlash free torque transmission required? <input type="checkbox"/> Yes <input type="checkbox"/> No	
4. Arrangement as <input type="checkbox"/> Shaft coupling (with co-axial shafts) Input side: Shaft diameter _____ mm Length _____ mm Output side: Shaft diameter _____ mm Length _____ mm <input type="checkbox"/> Built-on coupling, on <input type="checkbox"/> Shaft end: Diameter _____ mm Length _____ mm <input type="checkbox"/> Through-shaft dia.: Diameter _____ mm Length _____ mm Torque Limiter connects shaft with <input type="checkbox"/> Gear wheel <input type="checkbox"/> Chain wheel <input type="checkbox"/> Pulley <input type="checkbox"/> Other _____	
5. Drive via <input type="checkbox"/> Asynchronous motor <input type="checkbox"/> Direct drive <input type="checkbox"/> *Δ-drive <input type="checkbox"/> Other electric motor, type: _____ <input type="checkbox"/> Combustion engine Type _____ No. of cylinders _____ <input type="checkbox"/> Other _____	
6. Output and speed Output power _____ kW Speed of torque limiter _____ min ⁻¹ <input type="checkbox"/> Total output power via torque limiter <input type="checkbox"/> Output power only up to _____ % via torque limiter	
7. Output side Part of machine driven by the torque limiter _____ Required torque load _____ Nm In case of irregular torque requirement from _____ Nm to _____ Nm, frequency _____ Hz During starting a maximum torque of _____ Nm may occur How often will an overload occur? _____ times per year Preset limit torque _____ Nm (Limit torque must be 15 % above maximum operating torque)	
8. Installation conditions <input type="checkbox"/> In enclosed machine housing <input type="checkbox"/> Exposed, but in enclosed space <input type="checkbox"/> In oil bath or oil fog <input type="checkbox"/> Outside, ambient temperatures from _____ to _____ °C <input type="checkbox"/> Other (accessibility, dust, etc.): _____ <input type="checkbox"/> If arranged as shaft coupling: Max. parallel displacement of shafts _____ mm Max. angular displacement _____ degrees Distance between shaft ends _____ mm	
9. Overload signal by <input type="checkbox"/> Proximity switch <input type="checkbox"/> Non-contact proximity switch <input type="checkbox"/> Mechanical proximity switch <input type="checkbox"/> Not necessary	
10. For the selection of the torque limiter particular consideration should be given to the following: _____	
11. Estimated requirement _____ pieces (one off application) _____ pieces/month _____ pieces/year	

Questionnaire for the selection of RINGSPANN Force Limiters

Please photocopy or use the PDF-File from our website!

Company: Address: Phone: Fax:	Department: Name: Enquiry Ref.: Date: E-mail:									
1. Type of machine into which the Force Limiter is to be installed										
2. Force Limiter use In the case of overload the force limiter must: <input type="checkbox"/> Disengage <input type="checkbox"/> Only follow a particular path without disengaging <input type="checkbox"/> Trigger an electrical signal										
3. Force Limiter function In the case of overload the force limiter must: <input type="checkbox"/> Operate or disengage in both directions <input type="checkbox"/> Only operate or disengage if there is compressive load <input type="checkbox"/> Only operate or disengage if there is tensile load										
4. Manifestation of force <input type="checkbox"/> Adjustment of disengaging force: Disengaging force F_A : N <table style="width: 100%; border: none;"> <tr> <td></td> <td style="text-align: center;">upon pull</td> <td style="text-align: center;">upon pressure</td> </tr> <tr> <td>Operating force [N]</td> <td style="text-align: center;">_____</td> <td style="text-align: center;">_____</td> </tr> <tr> <td>Disengagement path [mm]</td> <td style="text-align: center;">_____</td> <td style="text-align: center;">_____</td> </tr> </table> <ul style="list-style-type: none"> • Operating force is the force which the Force Limiter has to transmit without disengaging or following a particular path. • Disengagement path is the maximum change in length of the Force Limiter when it disengages. 			upon pull	upon pressure	Operating force [N]	_____	_____	Disengagement path [mm]	_____	_____
	upon pull	upon pressure								
Operating force [N]	_____	_____								
Disengagement path [mm]	_____	_____								
5. Connection <input type="checkbox"/> Standard types as per catalogue <input type="checkbox"/> With rod connection as per sketch <input type="checkbox"/> With housing connection as per sketch										
6. Installation conditions <input type="checkbox"/> In enclosed machine housing <input type="checkbox"/> Exposed, but in enclosed space <input type="checkbox"/> In oil bath or oil fog <input type="checkbox"/> Outside, ambient temperatures from _____ to _____ °C <input type="checkbox"/> Other (e.g. accessibility, dust and other environmental factors which may be significant): _____										
7. Proximity switch <input type="checkbox"/> Without proximity switch <input type="checkbox"/> Complete with installed and adjusted proximity switch <input type="checkbox"/> With location borehole for proximity switch										

Germany

RINGSPANN GmbH

Schaberweg 30 - 38, 61348 Bad Homburg, Germany
+49 6172 275 0
info@ringspann.de • www.ringspann.de

RINGSPANN RCS GmbH

Hans-Mess-Straße 7, 61440 Oberursel, Germany
+49 6172 67 68 50
info@ringspann-rcs.de • www.ringspann-rcs.de

France

SIAM - RINGSPANN S.A.

23 rue Saint-Simon, 69009 Lyon, France
+33 4 78 83 59 01
info@siam-ringspann.fr • www.ringspann.fr

Great Britain, Ireland

RINGSPANN (U.K.) LTD.

3, Napier Road, Bedford MK41 0QS, Great Britain
+44 1234 3425 11
info@ringspann.co.uk • www.ringspann.co.uk

Italy

RINGSPANN Italia S.r.l.

Via A.D. Sacharov, 13, 20812 Limbiate (MB), Italy
+39 02 93 57 12 97
info@ringspann.it • www.ringspann.it

Netherlands, Belgium, Luxembourg

RINGSPANN Benelux B.V.

Nieuwenkampsmaten 6-15, 7472 DE Goor,
Netherlands • +31 547 26 13 55
info@ringspann.nl • www.ringspann.nl

Austria, Hungary, Slovenia

RINGSPANN Austria GmbH

Triesterstraße 21, 2620 Neunkirchen, Austria
+43 26 35 624 46
info@ringspann.at • www.ringspann.at

Poland

Radius-Radpol Wiecheć Sp.J.
Ul. Pasjonatów 3, 62-070 Dąbrowa, Poland
+48 61 814 39 28 • info@radius-radpol.com.pl
www.radius-radpol.com.pl

Romania, Bulgaria, Moldova

S.C. Industrial Seals and Rolls S.R.L.
Str. Depozitelor, No. 29, 110078 Pitesti, Romania
+4 0751 22 82 28
mihai@isar.com.ro • www.isar.com.ro

Sweden, Finland, Denmark,
Norway, Baltic states**RINGSPANN Nordic AB**

Flottiljgatan 69, 721 31 Västerås, Sweden
+46 156 190 98
info@ringspann.se • www.ringspann.se

Switzerland

RINGSPANN AG

Sumpfstrasse 7, P.O. Box, 6303 Zug,
Switzerland • +41 41 748 09 00
info@ringspann.ch • www.ringspann.ch

Spain, Portugal

RINGSPANN IBERICA S.A.

C/Uzbina, 24-Nave E1, 01015 Vitoria, Spain
+34 945 22 77-50
info@ringspann.es • www.ringspann.es

Czech Republic, Slovakia

Ing. Petr Schejbal
Mezivříší 1444/27, 14700 Prag, Czech Republic
+420 222 96 90 22
Petr.Schejbal@ringspann.cz • www.ringspann.com

Ukraine

"START-UP" LLC.
Saltivske Hwy, 43, letter G-3, office 101,
Kharkiv 61038, Ukraine • +38 057 717 03 04
start-up@start-up.kh.ua • www.start-up.kh.ua

Asia

Australia, New Zealand

RINGSPANN Australia Pty Ltd

Unit 5, 13A Elite Way, Carrum Downs Vic 3201,
Australia • +61 3 9069 0566
info@ringspann.com.au • www.ringspann.com.au

China, Taiwan

RINGSPANN Power Transmission (Tianjin) Co., Ltd.

No. 21 Gaoyan Rd., Binhai Science and Technology
Park, Binhai Hi-Tech Industrial, Development Area,
Tianjin, 300458, P.R. China • +86 22 5980 31 60
info.cn@ringspann.cn • www.ringspann.cn

India, Bangladesh, Nepal

RINGSPANN Power Transmission India Pvt. Ltd.

GAT No: 679/2/1, Village Kuruli, Taluka Khed, Chakan-
Alandi Road, Pune - 410501, Maharashtra, India
+91 21 35 67 75 00 • info@ringspann-india.com
www.ringspann-india.com

Singapore, ASEAN

RINGSPANN Singapore Pte. Ltd.

143 Cecil Street, #17-03 GB Building,
Singapore 069542 • +65 9633 6692
info@ringspann.sg • www.ringspann.sg

South Korea

RINGSPANN Korea Ltd.

33 Gojae-17 Ghil Dongnam-gu, 31187 Cheonan-si
Chungnam, South Korea • +82 10 54961 368
info@ringspann.kr • www.ringspann.kr

America

Brazil

Antares Acoplamentos Ltda.
Rua Evaristo de Antoni, 1222, Caxias do Sul, RS,
CEP 95041-000, Brazil • +55 54 32 18 68 00
vendas@antaresacoplamentos.com.br
www.antaresacoplamentos.com.br

Chile, Peru, Colombia, Ecuador

RINGSPANN Sudamérica SpA

Miraflores 222, Piso 28-N, Santiago,
Región Metropolitana, Chile • +56 9 8414 4078
info@ringspannsudamerica.com
www.ringspannsudamerica.com

USA, Canada, Mexico

RINGSPANN Corporation

10550 Anderson Place, Franklin Park, IL 60131, USA
+1 847 678 35 81
info@ringspanncorp.com •
www.ringspanncorp.com

Africa and Middle East

Egypt

Shofree Trading Co.
218 Emtedad Ramsis 2, 2775 Nasr City, Cairo, Egypt
+20 2 20 81 20 57
info@shofree.com • www.ringspann.com

Israel

G.G. Yarom Rolling and Conveying Ltd.
6, Hamaktsh Str., 58810 Holon, Israel
+972 3 557 01 15
noam_a@gg.co.il • www.ringspann.com

South Africa, Sub-Saharan

RINGSPANN South Africa (Pty) Ltd.

96 Plane Road Spartan, Kempton Park,
P.O. Box 8111 Edenglen 1613, South Africa
+27 11 394 18 30
info@ringspann.co.za • www.ringspann.co.za

Iran

Persia Robot Machine Co. Ltd.
4th Floor, No 71, Mansour St, Motahari Avenue,
Tehran 15957, Iran • +98 21 887091 58-62
info@persiarobot.com • www.ringspann.com

Maghreb, West Africa

SIAM - RINGSPANN S.A.

23 rue Saint-Simon, 69009 Lyon, France
+33 4 78 83 59 01
info@siam-ringspann.fr • www.ringspann.fr